

بِسْمِ اللّٰهِ الرَّحْمٰنِ الرَّحِیْمِ

اَللّٰهُمَّ صَلِّ عَلٰى مُحَمَّدٍ وَّ اٰلِ مُحَمَّدٍ وَّ عَجِّلْ فَرَجَهُمْ



English for Schools **PROSPECT**

2

Junior Secondary Prevocational Program



لا حول ولا قوة الا بالله العلي العظيم

به نام خدا

یکی از اهداف کلیدی سند تحول بنیادین آموزش و پرورش، پرورش تربیت‌یافتگانی است که از دانش‌های پایه و عمومی سازگار با نظام معیار اسلامی برخوردار گردند و با روحیه مسئولیت‌پذیری و تعالی‌خواهی و برخوردار از مهارت‌های ارتباطی، در حیات خانوادگی و اجتماعی با رعایت اصول برگرفته از نظام معیار اسلامی، مشارکت مؤثر داشته باشند. زمینه تحقق چنین هدفی را راهکارهای مبتنی بر نظریه و پژوهش‌بنیان، نظیر طراحی، تدوین و بازتولید برنامه‌های درسی موجود با تأکید بر متناسب‌سازی حجم و محتوای کتب درسی و ساعات و روزهای آموزشی با توانمندی‌ها و ویژگی‌های دانش‌آموزان فراهم می‌کند.

بر این اساس سازمان آموزش و پرورش استثنایی کشور در مسیر اجرای سند تحول بنیادین آموزش و پرورش و به پشتوانه اهداف مندرج در اساسنامه خود، اقدام به تدوین محتوای کتب نوآموزان و دانش‌آموزان با نیازهای ویژه، مبتنی بر برنامه درسی ملی نموده است. در طراحی و تدوین محتوا برای این گروه از دانش‌آموزان، ضمن توجه به ویژگی‌های شناختی، حسی، جسمی و هیجانی نوآموزان و دانش‌آموزان تلاش گردیده تا ملاحظات ساحت‌های تربیتی حاکم بر فلسفه تعلیم و تربیت که ناظر به رشد و توانمندی دانش‌آموزان برای درک و فهم دانش پایه و عمومی، کسب مهارت‌های دانش‌افزایی، به کارگیری شیوه تفکر علمی و منطقی، توان تفکر انتقادی، آمادگی جهت بروز خلاقیت، بینش و تفکر فناورانه برای بهبود کیفیت زندگی است، مورد توجه قرار گیرد تا زمینه‌های مساعد برای به فعلیت رساندن استعدادها و توانایی‌های آنان را فراهم سازد.

سازمان آموزش و پرورش استثنایی بر خود واجب می‌داند از تلاش و مساعی تمامی گروه‌های تألیف کتاب‌های درسی و همکاران سازمان پژوهش و برنامه‌ریزی آموزشی وزارت متبوع که در مراحل چاپ و آماده‌سازی ما را یاری داده‌اند، تقدیر و تشکر نماید.

امید است معلمان، کارشناسان و صاحب‌نظران آموزش و پرورش با نظرات و پیشنهادهای ارزشمند خود این سازمان را در ارتقاء کیفیت این محتوا یاری رسانند.

معاون وزیر و رئیس سازمان آموزش و پرورش استثنایی کشور

سخنی با همکاران

پس از تدوین سند تحول بنیادین آموزش و پرورش و استقرار ساختار جدید نظام آموزشی، سازمان آموزش و پرورش استثنایی نیز همگام با سایر بخش‌های وزارت آموزش و پرورش اقدام به برنامه‌ریزی به منظور تحقق اهداف سند تحول نموده است. در این راستا، مطابق با اهداف پیش‌بینی شده در برنامه درسی ملی و به منظور کیفیت‌بخشی به آموزش و پرورش دانش‌آموزان با نیازهای ویژه، تحقق عدالت آموزشی و بهبود و اصلاح محتوا و روش‌های آموزشی؛ در گام نخست کتاب‌های درسی مورد بررسی و ارزشیابی قرار گرفت. سپس کتاب زبان انگلیسی با توجه به یافته‌های علمی، ویژگی‌ها و نیازهای دانش‌آموزان دوره اول متوسطه پیش‌حرفه‌ای تألیف شد. در جلد نخست، برخی از حروف، صداها، مفاهیم و واژه‌ها، دستورات زبانی و اعداد معرفی گردید. کتاب پیش‌رو جلد دوم از مجموعه آموزش زبان انگلیسی است که با مروری بر مباحث آموزش داده شده در جلد نخست، آغاز می‌شود. این کتاب شامل نه درس، سه تمرین مروری و پیوست‌های آموزشی است. برای پیشبرد بهتر و تکمیل فرآیند یاددهی - یادگیری، مراجعه همکاران محترم به کتاب راهنمای معلم الزامی است. در ادامه ساختار کتاب به صورت مختصر معرفی می‌شود. شرح مبسوط مطالب در کتاب راهنمای معلم آمده است.

۱. تصویر عنوانی

تصویر عنوانی فضای کلی هر درس را ارائه می‌کند. هدف از تصویر عنوانی ارائه کلی محتوای هر درس به منظور ایجاد انگیزه در فراگیران و زمینه‌سازی برای گفت‌وگو درباره موضوع درس است. پیش از شروع هر درس، معلم با توصیف و ارائه سناریوی درس، دانش‌آموزان را برای یادگیری درس آماده می‌کند. به این ترتیب توجه دانش‌آموزان گاه به کلیات و گاه به جزئیات تصاویر جلب می‌شود و آگاهی بهتری نسبت به محتوای هر درس پیدا می‌کنند.

۲. متن درس

متن هر درس با تصاویر مرتبط و حباب سخن برای دانش‌آموزان ارائه شده است. در این بخش، واژگان هدف در تصویر به صورت موضوعی آورده شده و سپس به منظور توجه بیشتر دانش‌آموزان به محتوا، نگاره‌هایی نیز به همراه واژگان آورده شده است. برای آشنایی بهتر دانش‌آموزان با داستان کتاب، در هر درس شخصیت‌ها به صورت جداگانه معرفی شده‌اند. لذا آشنایی دانش‌آموزان با نام و تصویر شخصیت‌ها ضروری است.

۳. تمرین

برای توجه به سبک‌های مختلف یادگیری دانش‌آموزان، تمرین‌های متنوعی طراحی شده است که دانش‌آموزان پس از انجام تمرین به صورت انفرادی، باید در گروه‌های دو یا چند نفره تمرین‌ها را تکرار کنند. صورت دستوری برخی از تمرین‌ها به این قرار است: گوش کنید و اشاره کنید؛ گوش کنید و تکرار کنید؛ گوش کنید و عکس صحیح را انتخاب کنید؛ گوش کنید و بنویسید؛ حروف مشخص را پیدا کنید و دور آنها خط بکشید؛ تصاویر را به حروف ابتدایی‌شان وصل کنید؛ نوشتن لغات را تمرین کنید؛ به هر لغت اشاره کنید و از دوست خود بخواهید آن را بخواند و جای خالی اعداد را پر کنید.

۴. حروف

از درس یک تا پنج، در هر درس دو حرف به صورت کوچک و بزرگ به دانش‌آموزان آموزش داده می‌شود. تأکید بر این است که در ابتدا نگاره‌های واژه‌های مرتبط معرفی شوند تا دانش‌آموزان مفهوم هر واژه را درک کنند. پس از گوش دادن و تکرار کردن، دانش‌آموزان به استفاده از حروف در واژه‌ها در قالب «گوش کنید و آواز بخوانید» می‌پردازند. همچنین در سه درس پایانی دانش‌آموزان به فراگیری خواندن و نوشتن لغات خواهند پرداخت. در بخش تمرین مربوط به حروف، دانش‌آموزان نخست فعالیت‌های فردی را در قالب مهارت شنیداری، وصل کردن

تصاویر و بلندخوانی حروف تجربه می‌کنند. سپس فعالیت‌هایی را در قالب کار گروهی انجام می‌دهند. در بخش تمرین نوشتاری الگوهای صحیح نوشتاری حروف تدریس شده به صورت بزرگ و کوچک آورده شده است. به منظور تدریس نوشتار حروف، نحوه چرخش دست برای نوشتن هر یک از حروف آورده شده است. در بخش نوشتن، دانش‌آموزان پس از ردیابی و تمرین نوشتن حروف به صورت مستقل، می‌توانند جاهای خالی برخی از واژه‌ها را نیز با حروف مناسب پر کنند.

درس‌های شش تا نه به مرور حروف اختصاص یافته است که شامل تمرین‌های مختلف صورت نوشتاری، صدای حروف و همچنین خواندن واژه‌ها است که عبارتند از یافتن حروف، جست‌وجوی واژه‌ها، تکمیل واژگان و تکمیل جدول‌های ساده.

۵. اعداد

اعداد انگلیسی از «۱۱» تا «۶۰» آموزش داده می‌شوند که نحوه ارائه اعداد در درس‌های مختلف عبارتند از: آموزش اعداد «۱۱» تا «۲۰» در درس یک تا سه، آموزش اعداد «۲۱» تا «۶۰» در درس چهار تا هفت و مرور اعداد از «۰» تا «۶۰» در درس‌های هشت و نه.

تمرین‌های مربوط به اعداد شامل: گوش دادن، تکرار کردن، دایره کشیدن دور عدد صحیح و در نهایت نوشتن اعداد است. در بخش تمرین نوشتن اعداد، نحوه چرخش و توالی حرکت‌های دست مهم است. برای اعداد «۲۱» تا «۶۰» تمرین نوشتاری در نظر گرفته نشده است که معلم می‌تواند تمرین‌های مناسب را ارائه نماید. دانش‌آموزان پس از انجام تمرین‌های انفرادی به سمت انجام فعالیت‌های دو نفره هدایت می‌شوند.

۶. خودارزیابی

در پایان هر درس، برگه‌های خودارزیابی طراحی شده است که دانش‌آموزان با درج علامت ✓ می‌توانند دانسته‌های خود را تأیید کنند و با انجام تمرین‌های بیشتر نسبت به برطرف کردن نقاط ضعف خود اقدام نمایند.

۷. بخش مروری

به منظور تعمیق و تثبیت یادگیری و بررسی دوباره مطالب فراگرفته شده، در انتهای هر سه درس، تمرین‌های مروری آورده شده است تا دانش‌آموزان به تمرین مجدد مطالب بپردازند.

۸. فرهنگ تصویری

در بخش پایانی کتاب، تمامی واژه‌ها و جمله‌ها به صورت تصویری ارائه شده است.

۹. کاربردهای حروف و واژه‌ها

برای تمرین بیشتر نوشتن حروف و واژه‌ها کاربرگ‌هایی در پایان کتاب آورده شده است.

۱۰. فهرست دستورکارها

برای استفاده بهتر معلمان گرامی، تمامی دستورکارهای کتاب به صورت الفبایی همراه با ترجمه آنها ارائه شده است.

۱۱. متن بخش صوتی

متن تمامی فایل‌های صوتی در انتهای کتاب آمده است.

همچنین به منظور ارزیابی عملکرد هر یک از دانش‌آموزان، در کتاب راهنمای معلم برای هر درس برگه ارزشیابی پیشرفت آورده شده است که همکاران گرامی باید مطابق شیوه‌نامه ارائه شده در کتاب راهنمای معلم، یادگیری دانش‌آموزان را ارزشیابی کنند.

امیدواریم تدوین و تألیف این کتاب، برای این گروه از دانش‌آموزان مفید واقع گردد. از همکاران گرامی و صاحب‌نظران تقاضا می‌شود جهت بهبود و کیفیت‌بخشی به محتوای کتاب، نظرات سازنده و راهنمایی‌های ارزشمند خود را به کارشناسی برنامه‌ریزی درسی و آموزشی دانش‌آموزان دوره اول متوسطه پیش‌حرفه‌ای سازمان آموزش و پرورش استثنایی ارسال نمایند.

گروه نویسندگان

Table of Contents

	Vocabulary and Expression	Grammar	Pronunciation	Listening & Speaking	Reading & Writing
Review of Book 1			p. 1		
Lesson 1: Socializing P. 5	Good morning, Fine, Mr., Ms., Bye, lemon, lamp, key, kite Numbers 11, 12 & 13	The verb be: "am", "is" & "are" Pronouns: "I" & "you" Demonstrative pronoun: "This" <i>How are you?</i> <i>This is ...</i>	"K k" & "L l" "K" for <i>key</i> and <i>kite</i> "L" for <i>lemon</i> and <i>lamp</i>	Good morning, How are you?, Fine, This is Mr. /Ms., Bye	"K", "L" 11, 12 & 13
Lesson 2: My Family P. 20	mom, dad, brother, sister, fish, fire, robot, rain Numbers 14, 15 & 16	The verb be: "is" Demonstrative pronoun: "This" Possessive adjective: "my" <i>This is my ...</i>	"F f" & "R r" "F" for <i>fish</i> and <i>fire</i> "R" for <i>robot</i> and <i>rain</i>	This is my	"F", "R" 14, 15, 16
Lesson 3: My Body P. 33	head, face, hand, leg, back gift, grass, quiz, (the) Quran Numbers 17, 18, 19 & 20	The verb be: "is" Demonstrative pronoun: "This" Possessive adjective: "my" <i>This is my ...</i>	"G g" & "Q q" "G" for <i>gift</i> and <i>grass</i> "Q" for <i>quiz</i> and (<i>the</i>) <i>Quran</i>	This is my	"G", "Q" 17, 18, 19 & 20
Review 1			p. 46		
Lesson 4: The Weather P. 51	hot, cold, sunny, rainy, snowy sun, soup, yellow, yard Numbers 21-30	Yes/No questions <i>Is it ... ?</i> Yes, <i>it is.</i> <i>No, it isn't.</i>	"S s", "Y y" "S" for <i>sun</i> and <i>soup</i> "Y" for <i>yellow</i> and <i>yard</i>	<i>Is it ... ?</i> Yes, <i>it is.</i> <i>No, it isn't.</i>	"S", "Y" 21-30
Lesson 5: Commands P. 64	wall, window, box, taxi Numbers 31-40	Imperative sentences (positive and negative) <i>(Don't) open (your) ...</i> <i>(Don't) close (your) ...</i> <i>(Don't) clean (your) ...</i> Possessive adjective: "your" Wh-question word: "How old" <i>How old are you?</i>	"W w", "X x" "W" for <i>wall</i> and <i>window</i> , "X" for <i>box</i> and <i>taxi</i>	<i>(Don't) open (your) ...</i> <i>(Don't) close (your) ...</i> <i>(Don't) clean (your) ...</i>	"W", "X" 31-40

	Vocabulary and Expression	Grammar	Pronunciation	Listening & Speaking	Reading & Writing
Lesson 6: My House P. 76	kitchen, bedroom, bathroom, living room Numbers 41-50	Pronouns: “He” & “She” Yes/No questions <i>Is she in the ... ?</i> <i>Is he in the ... ?</i> Wh-question word: “where” <i>Where is she?</i> <i>Where is he?</i> Wh-question word: “How old” <i>How old is she?</i> <i>How old is he?</i> Preposition: “in” <i>She is in the</i> <i>He is in the</i>	Sound/Letter review 1	<i>This is the</i> <i>Is she in the ... ?</i> <i>Is he in the ... ?</i> <i>Where is she?</i> <i>Where is he?</i> <i>How old is she?</i> <i>How old is he?</i> <i>She is in the</i> <i>He is in the</i>	ant, cat, hat, map, jam, ink, fig 41-50
Review 2			p. 86		
Lesson 7: Public Places P. 91	bank, supermarket, mosque, hospital, school in, Numbers 51-60	Pronouns: “He” & “She” Yes/No question <i>Is she in the ... ?</i> <i>Is he in the ... ?</i> Wh-question word: “where” <i>Where is he?</i> <i>Where is she?</i> Wh-question word: “how old” <i>How old is she?</i> <i>How old is he?</i> Preposition: “in” <i>She is in the</i> <i>He is in the</i>	Sound/Letter review 2	<i>Is she in the ... ?</i> <i>Is he in the ... ?</i> <i>Where is he?</i> <i>Where is she?</i> <i>How old is she?</i> <i>How old is he?</i> <i>She is in the</i> <i>He is in the</i>	van, hen, pen, bed, ink, up 51-60
Lesson 8: My Classroom P. 103	pencil(s), notebook(s), chair(s), bag(s)	Plural form Wh-question word: “How many” <i>How many ... ?</i>	Sound/Letter review 3	<i>How many... ?</i>	bag, lamp, lemon, zoo, book, park, oven Number Review 1: 0-30
Lesson 9: Colors P. 113	black, white, pink, brown	Yes/No questions <i>Is it ... ?</i> <i>Yes, it is.</i> <i>No, it isn't.</i> Wh-question word: “What color” <i>What color is it?</i> <i>What color is the ... ?</i> <i>It is</i>	Sound/Letter review 4	<i>Is it ... ?</i> <i>Yes, it is.</i> <i>No, it isn't.</i> <i>What color is it?</i> <i>What color is the ... ?</i> <i>It is</i>	box, sun, gift, quiz, taxi, grass, yard, wall Number Review 2: 31-60
Review 3				p. 126	
Photo Dictionary				p. 134	
Sentences				p. 137	
List of Instructions				p. 142	
Worksheets for Letters				p. 146	
Worksheets for Words				p. 149	
Audio Scripts				p. 152	

Review of Book 1

Look at the pictures. Then, make your own dialogue.



Match the small letters with the capital letters.

- | | | | |
|---|---|---|---|
| t | • | • | U |
| u | • | • | P |
| d | • | • | O |
| p | • | • | T |
| o | • | • | D |

Look at the letters below and put the missing capital or small letter in each cell.

	V	c	A	e	N	j
1	C			2	E	
3	J			4		v
5		a		6		n

Write down the missing small letters or capital letters.

1. M 2. z 3. B 4. i 5. H

 Listen to the commands and act out what you hear.



Pair work

Point to each picture and ask your friend to name it.

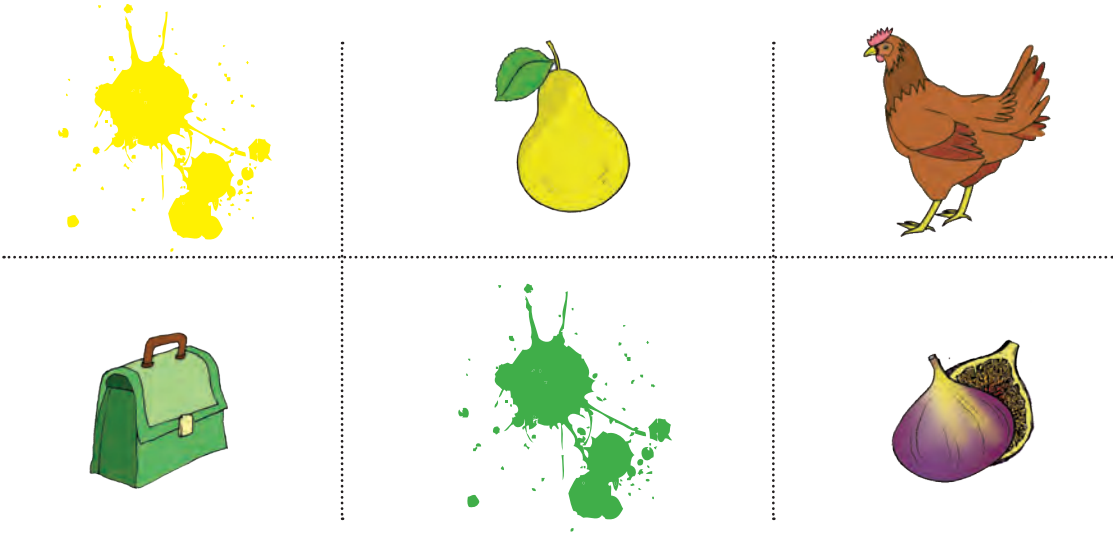

Find and circle the letters “e” and “p”.

oven zipper desk red egg
pen apple pear map park



Pair work

Point to each picture and ask your friend to write down the initial letter.

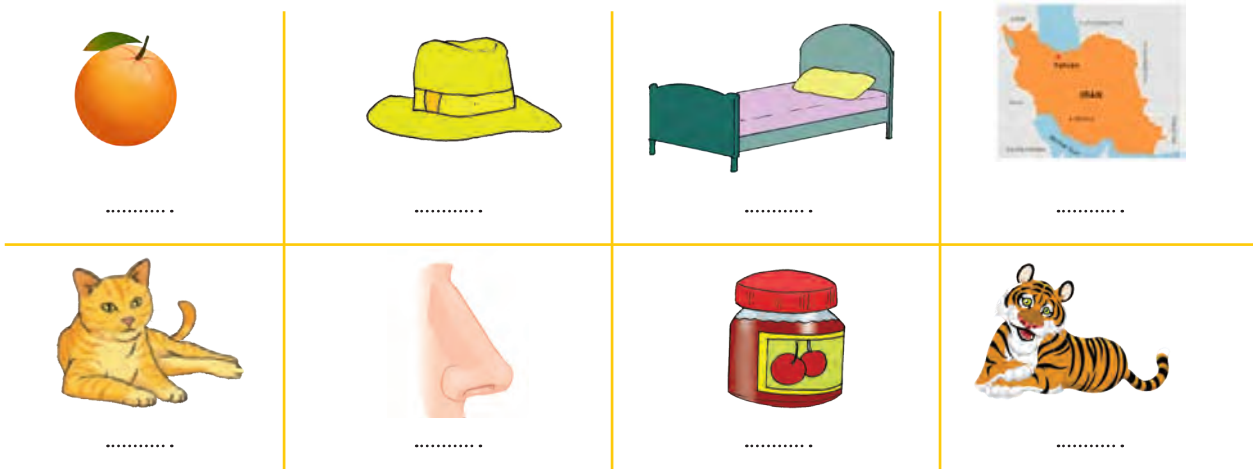

 Listen and write the missing letters.

1. ... andy

2. ... ea

3. ... mbrella

4. ... oo

5. ... ungle

6. ... an

 Listen and write the missing numbers.

12 ...

1 ... 3

11 ...

... 18

11 ...



Pair work

Say your phone number and ask your friend to write it down.

.....

Lesson 1

Socializing



Mina & Maryam

1 Listen.



Aa Bb Cc
Dd Ee Ff
Gg Hh Ii
Jj Kk Ll Mm
Nn Oo
Pp Qq Rr
Ss Tt Uu Vv
Ww Xx Yy Zz

1. Good morning, Maryam.
2. How are you?
3. Fine.

1. Good morning, Mina.
2. Fine, and you?



2 Listen and repeat.



Sara



Mina



Maryam



Pair work

Ask the students to greet each other using the pattern above.

Mina & Ms. Tavana

3  Listen.

Hello, Ms. Tavana.

This is Maryam.

Hello, Mina.

Hello, Maryam.

Hello, Ms. Tavana.







4  Listen and repeat.

Ms. Tavana

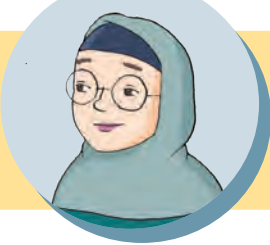

Practice

5  Listen and point.

1		
2		
3		
4		

6  Listen and repeat.

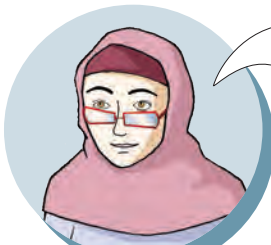
<p>1. Good morning, Ms. Tavana. 2. Fine.</p>			<p>Good morning, Sara. How are you?</p>
--	---	--	---



Pair work

Make your own dialogue using the pattern above.

7 Listen and repeat.



Pair work

Introduce yourself to the class. Then, introduce your friend.

Letters: K k & L l

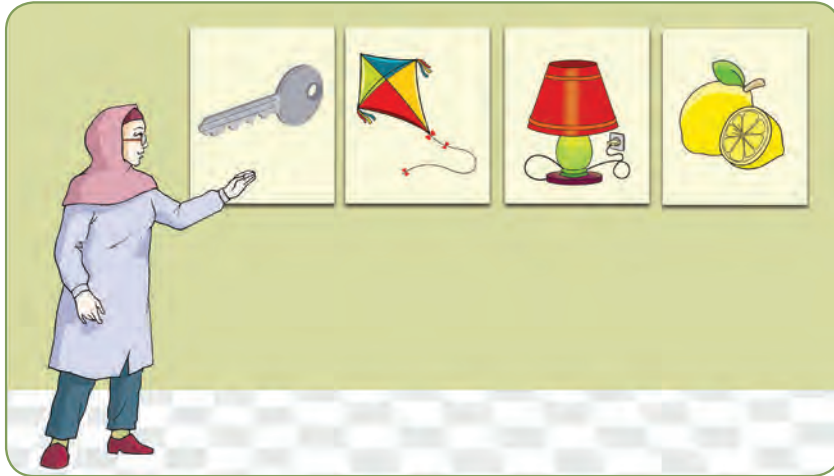

8 Listen and repeat.

K k L l

9 Listen and repeat.



key



lamp

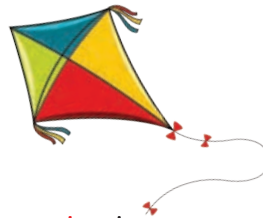

kite

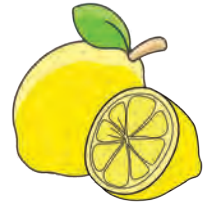

lemon

10 Listen again and point to the pictures above.

Sound out the letters in the words below.

“K” for

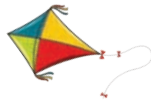

“L” for



“K” for



“L” for















11 Listen and chant.

It's a key; “k”, “k”, key.
It's a kite; “k”, “k”, kite.
It's a lamp; “l”, “l”, lamp.
It's a lemon; “l”, “l”, lemon.

Practice

12  Listen and choose the correct picture.

1	 <input type="checkbox"/>	 <input type="checkbox"/>	 <input type="checkbox"/>
2	 <input type="checkbox"/>	 <input type="checkbox"/>	 <input type="checkbox"/>
3	 <input type="checkbox"/>	 <input type="checkbox"/>	 <input type="checkbox"/>
4	 <input type="checkbox"/>	 <input type="checkbox"/>	 <input type="checkbox"/>

13  Listen and circle.



k / l

k / l



Listen and circle the initial letters.

1	key	lamp
2	lemon	kite

Match the pictures with the initial letters.

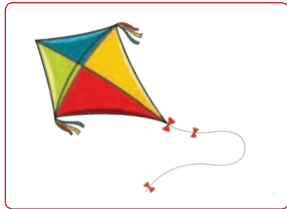
	k
	l

Read aloud.

K k L l



Pair work

Point to each picture and ask your friend to name it.







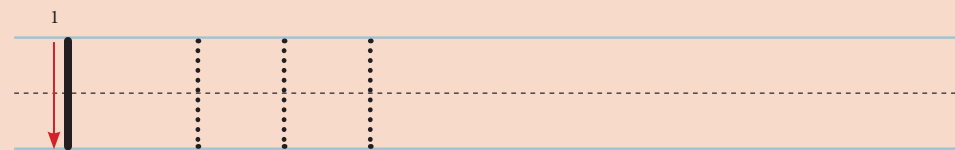
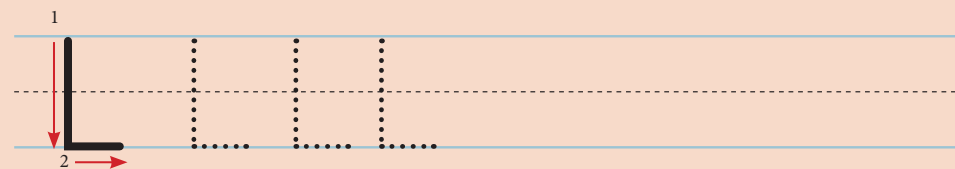
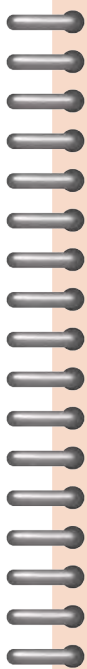
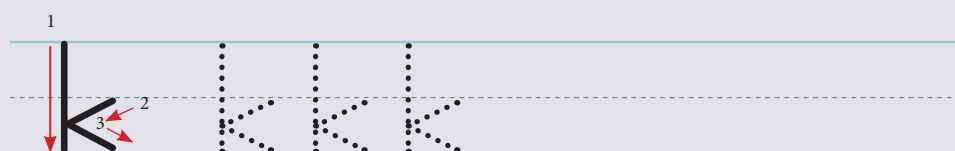
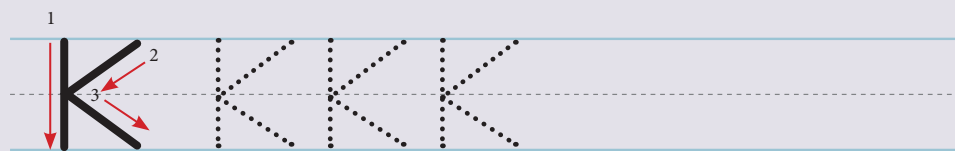
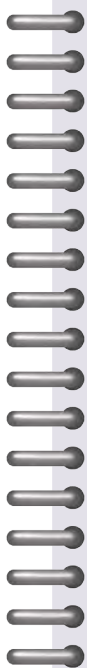
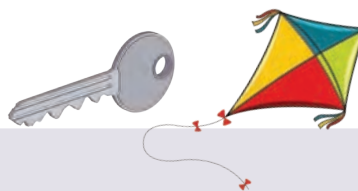

Writing Pad

Trace and write the letters.

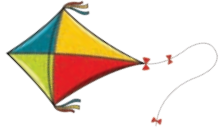
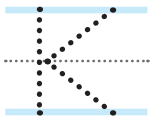
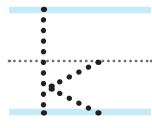

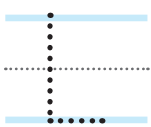
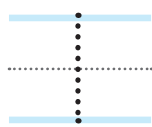

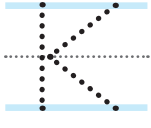
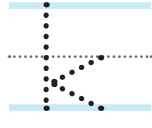
Practice

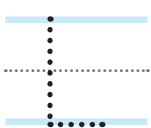
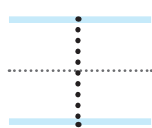

15  Listen and trace.

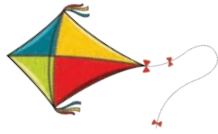
1			
2			
3			
4			

16  Listen and write the missing letters.

			
1. ...ey	2. ...emon	3. ...ite	4. ...amp

Look at the pictures and write the initial letters.

	
_____	_____
_____	_____
_____	_____

Numbers: 11, 12 & 13

17  Listen and repeat.



Practice

Circle number 11, 12 and 13.

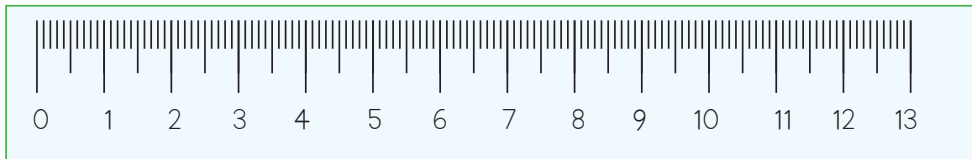

Pair work

Point to each number and ask your friend to read it.



Writing Pad

Trace and write the numbers.

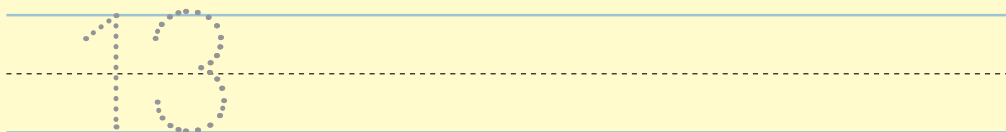
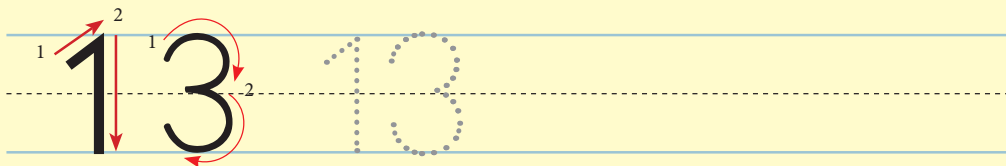
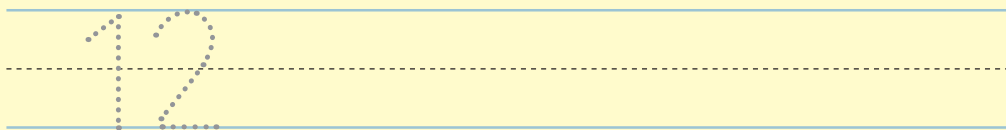
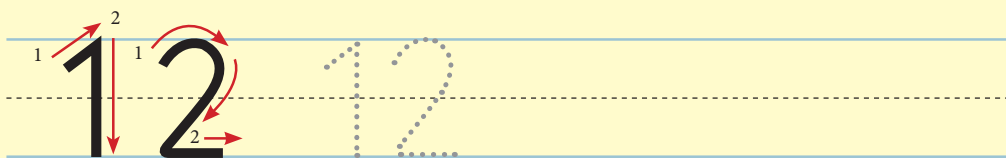
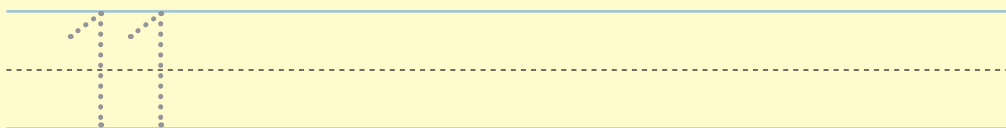
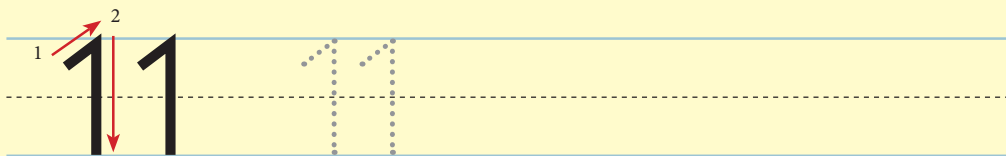

Practice

Write the missing numbers.



18  Listen and write.

A

.....

B

.....

C

.....

Bye

19  Listen.

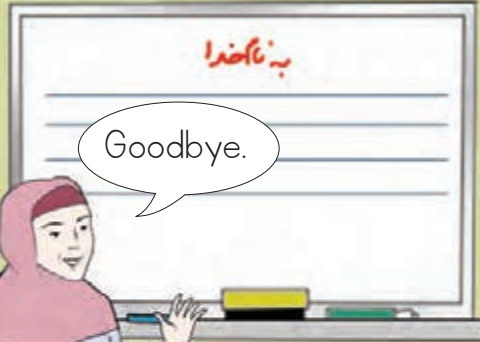

- Aa Bb Cc
- Dd Ee Ff
- Gg Hh Ii
- Jj Kk Ll Mm
- Nn Oo
- Pp Qq Rr
- Ss Tt Uu Vv
- Ww Xx Yy Zz

Goodbye.

Goodbye.

Bye.

Bye.



20  Listen and number the pictures as you hear.





Pair work

Say "Bye" to your friend and "Goodbye" to your teacher.



Self - Check

Check (✓) your learning.

1. Conversation

2. Vocabulary

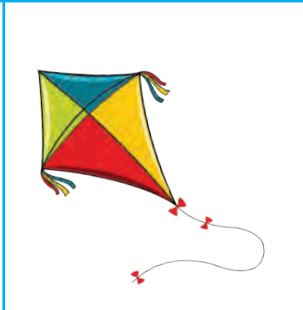
3. Letters

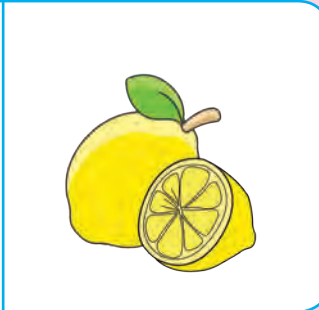
K k	L l

4. Numbers

11	12	13

Lesson 2

My Family



Family Members

1 Listen.

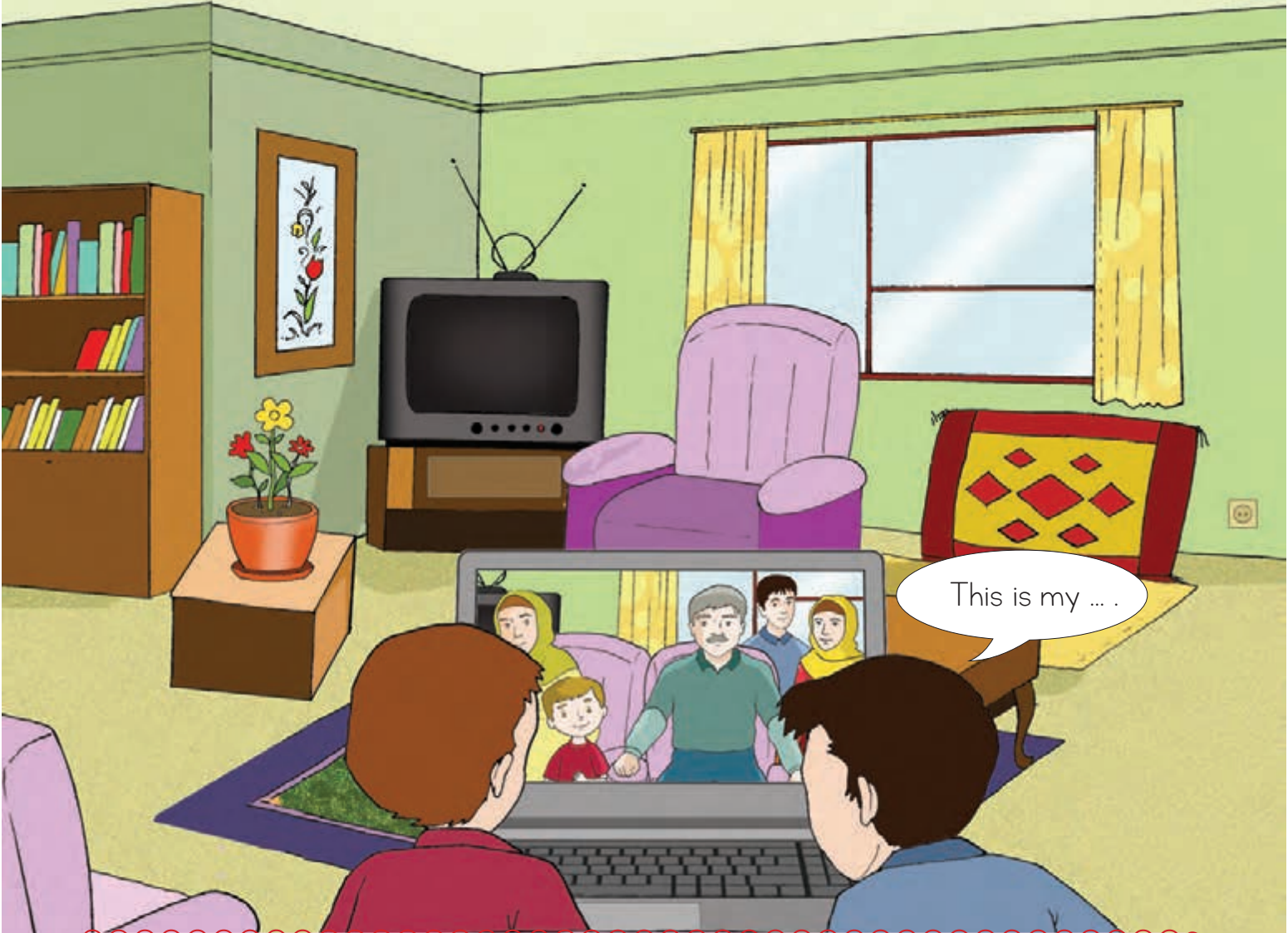

2 Listen and repeat.



mom



dad



brother

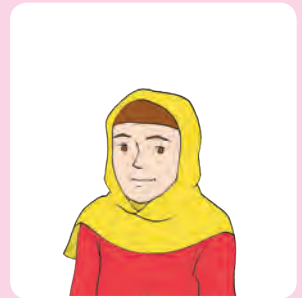





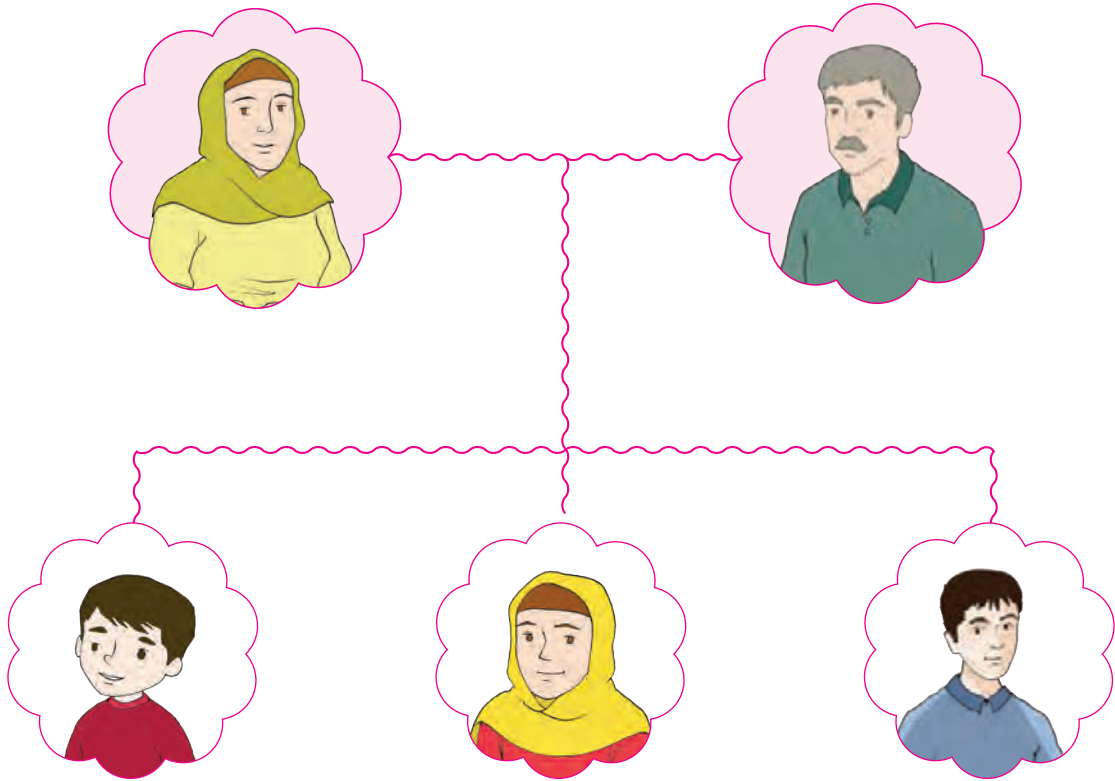

sister

Practice

3  Listen and point.

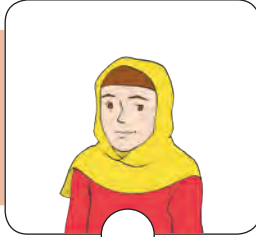
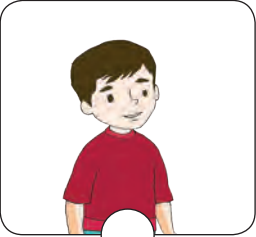

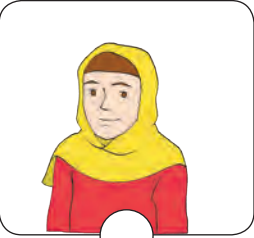
4  Listen and check the correct picture.

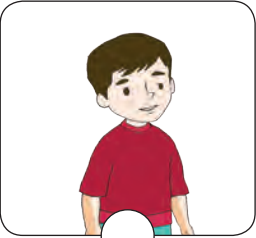
1			2		
3			4		

5  Listen and number the pictures.

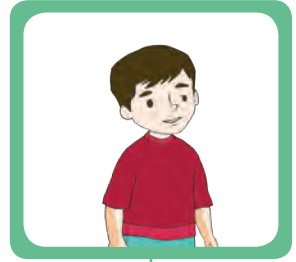
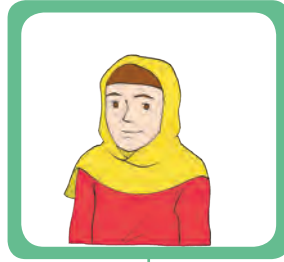

Pair work

Stick a photo of your family and introduce them.

Letters: F f & R r



6  Listen and repeat.

F f R r

7  Listen and repeat.



fish



robot



fire



rain

8  Listen again and point to the pictures above.

Sound out the letters in the words below.

“F” for



“R” for



“F” for



“R” for



9  Listen and chant.

It's a fish; “f”, “f”, fish.
It's a fire; “f”, “f”, fire.
It's a robot; “r”, “r”, robot.
It's the rain; “r”, “r”, rain.

Practice

10  Listen and choose the correct picture.

1	 <input type="checkbox"/>	 <input type="checkbox"/>	 <input type="checkbox"/>
2	 <input type="checkbox"/>	 <input type="checkbox"/>	 <input type="checkbox"/>
3	 <input type="checkbox"/>	 <input type="checkbox"/>	 <input type="checkbox"/>
4	 <input type="checkbox"/>	 <input type="checkbox"/>	 <input type="checkbox"/>

11  Listen and circle.



f / r

f / r

12  Listen and circle the initial letters.

1	fish	rain
2	fire	robot

Match the pictures with the initial letters.

	r
	f

Read aloud.

F f R r



Pair work

Point to each picture and ask your friend to name it.



Writing Pad

Trace and write the letters.















Handwriting practice for the letter 'F'. The first row shows a solid uppercase 'F' with stroke order arrows: 1 (vertical down), 2 (top horizontal right), and 3 (middle horizontal right). This is followed by three dotted uppercase 'F's for tracing. The second row shows a solid lowercase 'f' with stroke order arrows: 1 (curved top) and 2 (vertical down). This is followed by three dotted lowercase 'f's for tracing. The page includes a spiral binding on the left and horizontal writing lines.



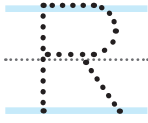

Handwriting practice for the letter 'R'. The first row shows a solid uppercase 'R' with stroke order arrows: 1 (vertical down), 2 (top curve), and 3 (bottom leg). This is followed by three dotted uppercase 'R's for tracing. The second row shows a solid lowercase 'r' with stroke order arrows: 1 (vertical down) and 2 (curved top). This is followed by three dotted lowercase 'r's for tracing. The page includes a spiral binding on the left and horizontal writing lines.

Practice

13  Listen and trace.

1			
2			
3			
4			

14  Listen and write the missing letters.

			
1. ...obot	2. ...ire	3. ...ain	4. ...ish

Look at the pictures and write the initial letters.

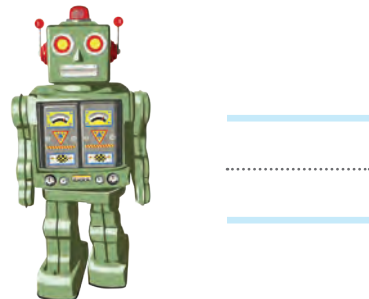

Numbers: 14, 15 & 16

15  Listen and repeat.



Practice

Circle number 14, 15 and 16.

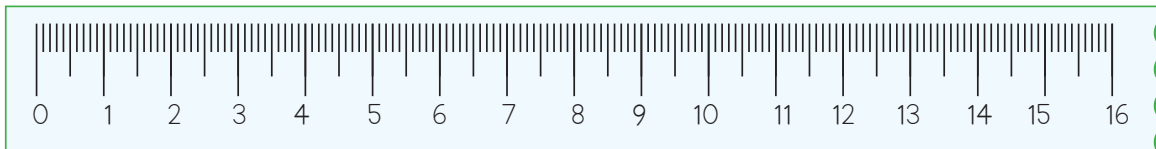

Pair work

Point to each number and ask your friend to read it.

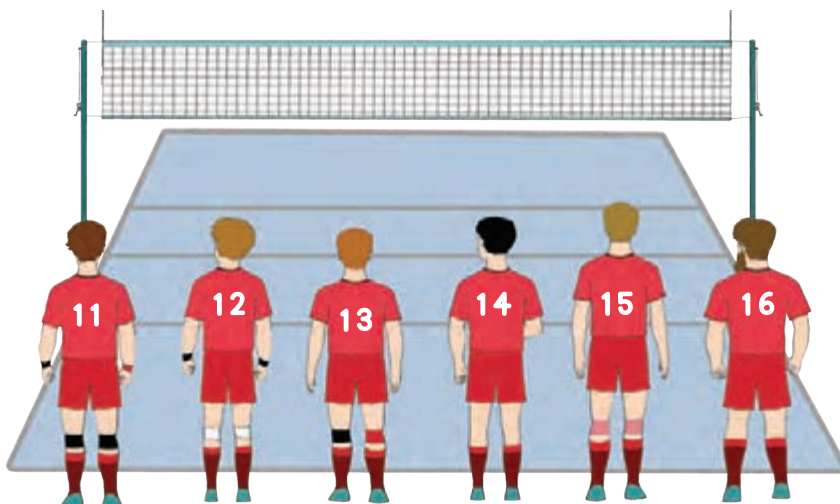

Writing Pad

Trace and write the numbers.

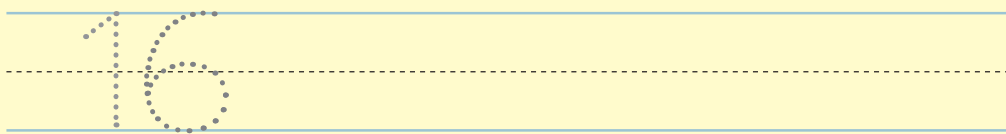
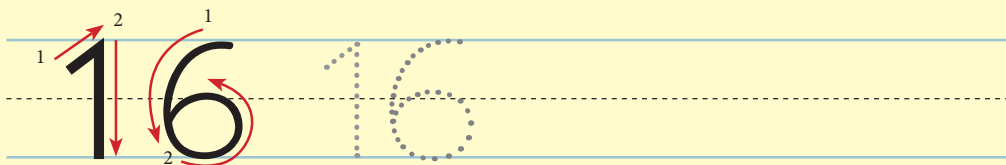
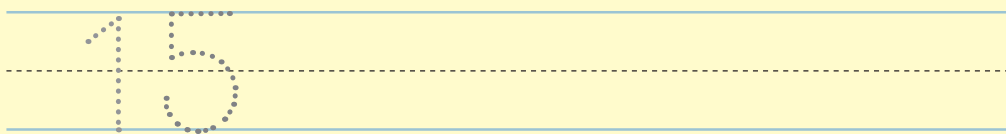
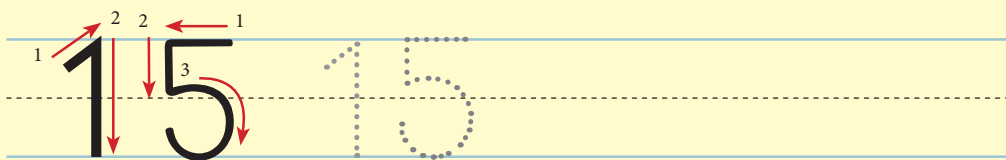
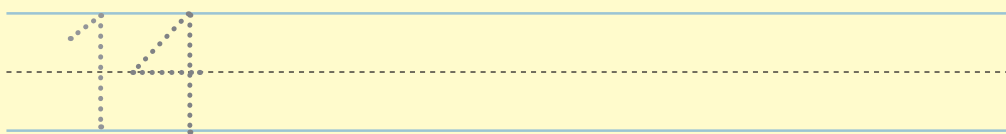
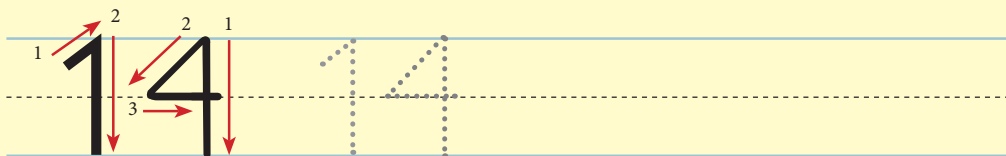

Practice

Write the missing numbers.







16  Listen and write.





A	<hr/>	<hr/>	<hr/>
	<hr/>	<hr/>	<hr/>
	<hr/>	<hr/>	<hr/>
B	<hr/>	<hr/>	<hr/>
	<hr/>	<hr/>	<hr/>
	<hr/>	<hr/>	<hr/>

Self - Check

Check (✓) your learning.

1. Vocabulary

2. Letters

F f	R r

3. Numbers

14	15	16

Lesson 3

My Body

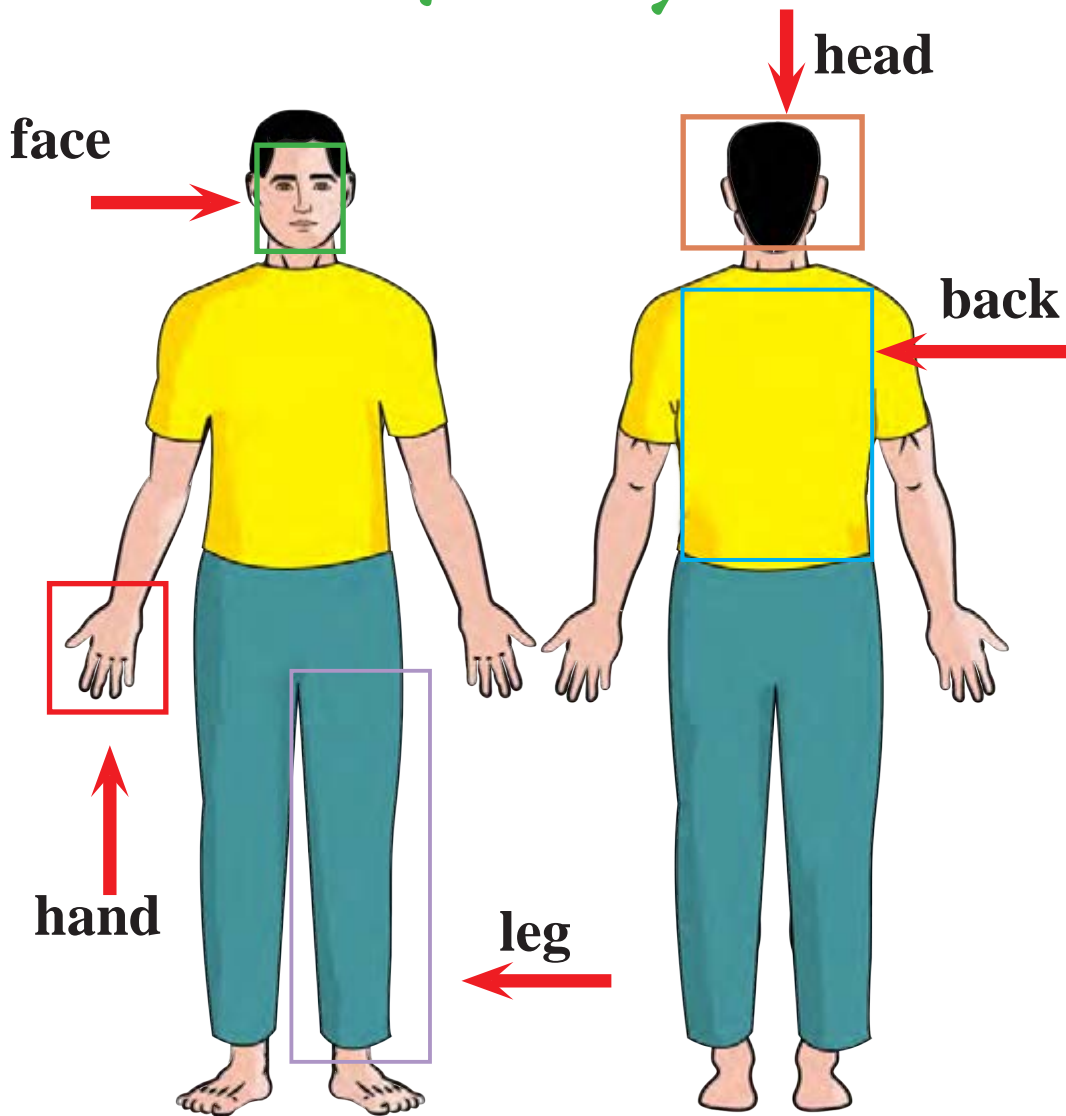

Parts of Body

1 Listen.



This is my head.

Aa Bb Cc
Dd Ee Ff
Gg Hh Ii
Jj Kk Ll Mm
Nn Oo
Pp Qq Rr
Ss Tt Uu Vv
Ww Xx Yy Zz

2 Listen and repeat.



head

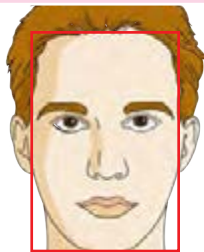

face



hand

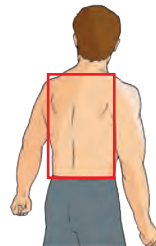

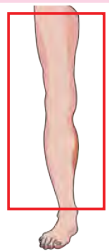

back



leg

Practice

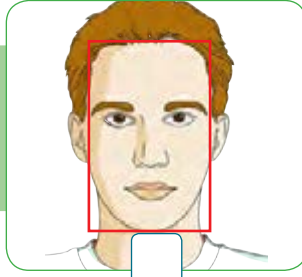
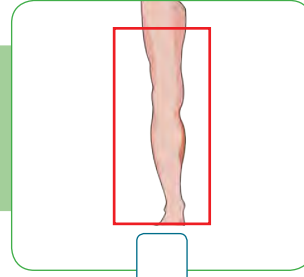
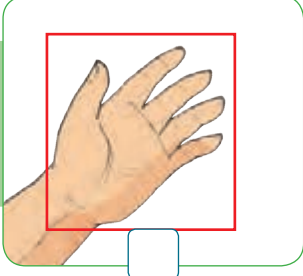
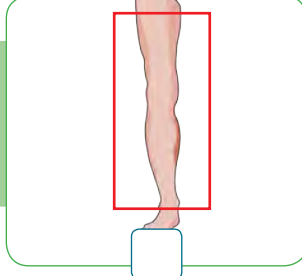
3  Listen and choose the correct picture.

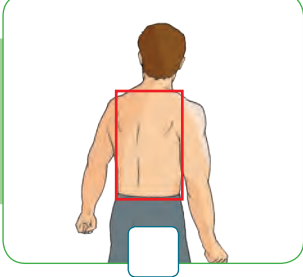
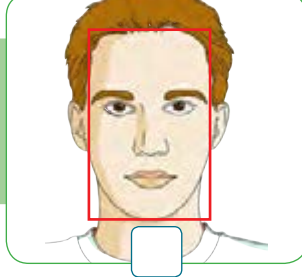
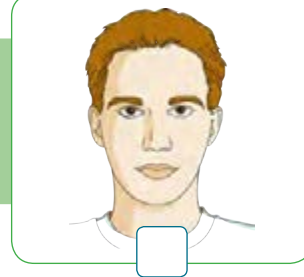
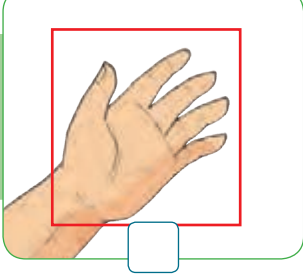
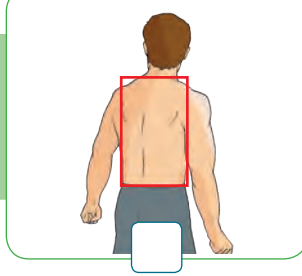
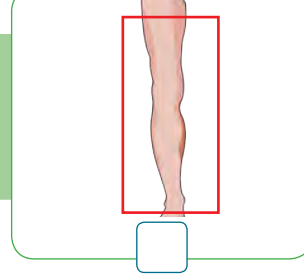
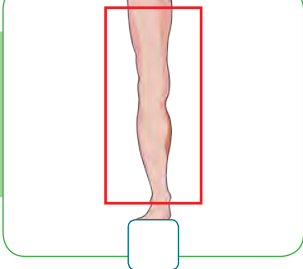
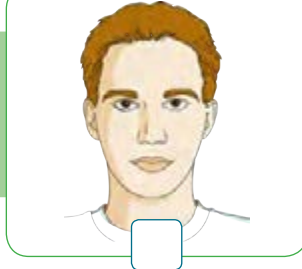
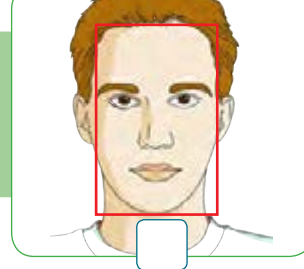
1			
2			
3			
4			
5			



Listen and number the body parts from 1 to 4.

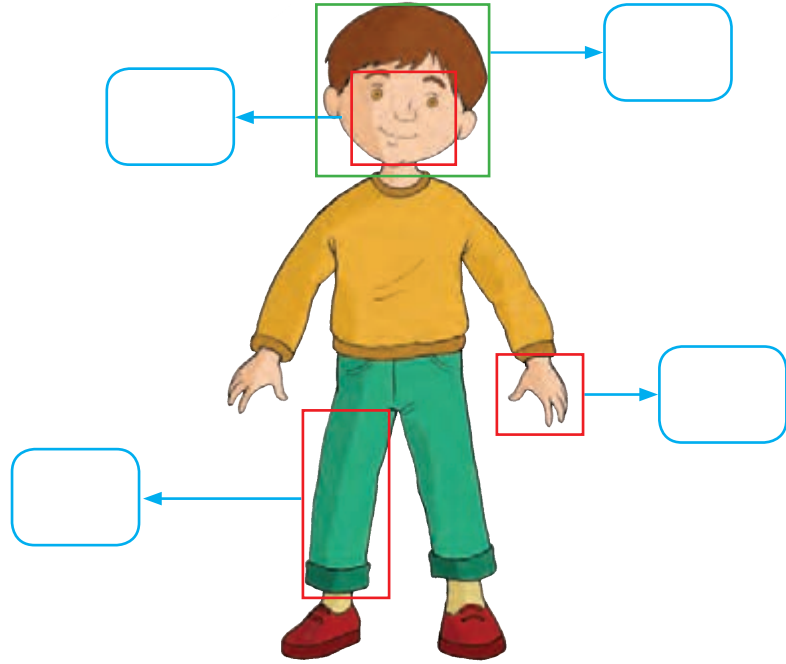

Pair work

Point to each body part and ask your friend to name it.

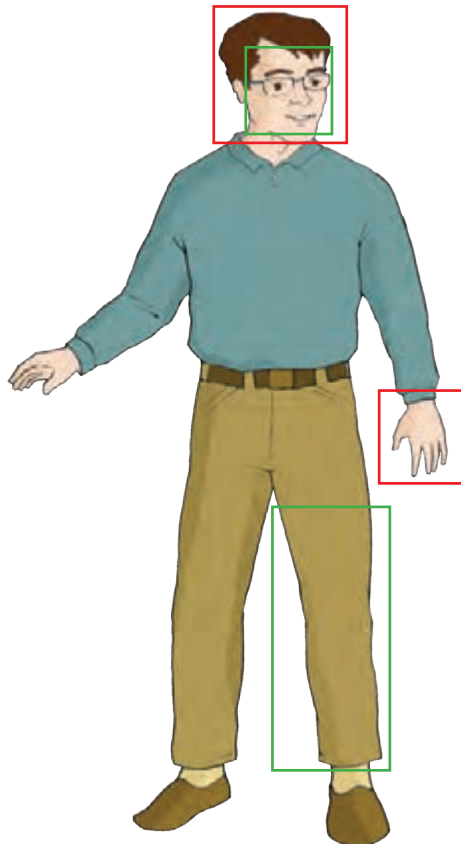

Letters: Gg & Qq



5 Listen and repeat.

G g Q q

6 Listen and repeat.



Quran

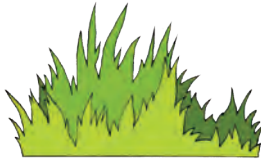

grass



quiz



gift

7 Listen again and point to the pictures above.

Sound out the letters in the words below.

“G”

for



“Q”

for



“G”

for



“Q”

for



8 Listen and chant.

It's a gift; “g”, “g”, gift.







It's grass; “g”, “g”, grass.

It's a quiz; “q”, “q”, quiz.

It's the Quran; “q”, “q”, Quran.

Practice

9  Listen and choose the correct picture.

1	 <input type="checkbox"/>	 <input type="checkbox"/>	 <input type="checkbox"/>
2	 <input type="checkbox"/>	 <input type="checkbox"/>	 <input type="checkbox"/>
3	 <input type="checkbox"/>	 <input type="checkbox"/>	 <input type="checkbox"/>
4	 <input type="checkbox"/>	 <input type="checkbox"/>	 <input type="checkbox"/>

10  Listen and circle.

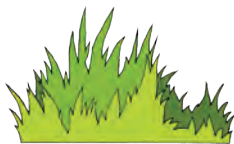

g / q



g / q

 Listen and circle the initial letters.

1	gift	Quran
2	grass	quize

Match the pictures with the initial letters.

	q
	g

Read aloud.

G g Q q



Pair work

Point to each picture and ask your friend to name it.







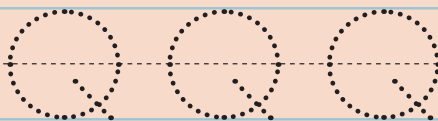
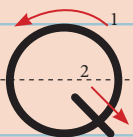
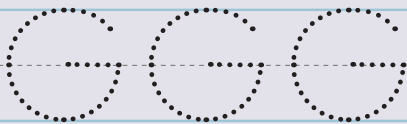

Writing Pad

Trace and write the letters.

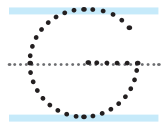
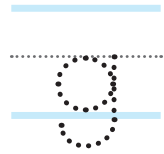

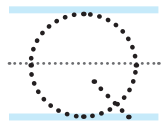
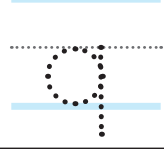
Practice

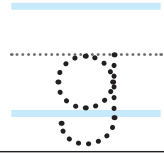
12  Listen and trace.

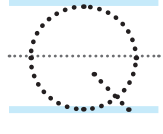
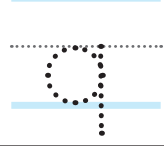
1			
2			
3			
4			

13  Listen and write the missing letters.

			
1. ...ift	2. ...uran	3. ...uiz	4. ...rass

Look at the pictures and write the initial letters.





Numbers: 17, 18, 19 & 20

14  Listen and repeat.



Practice

Circle number 17, 18, 19 and 20.

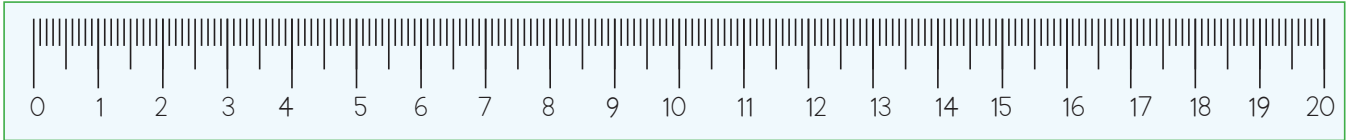

Join the numbers and name the pictures.

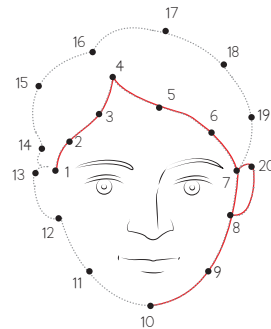
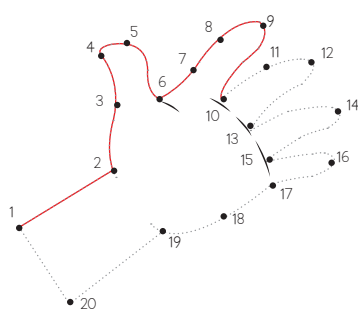

Pair work

Point to each number and ask your friend to read it.

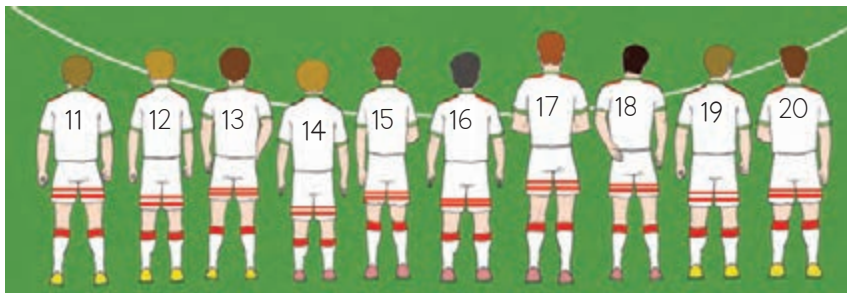

Writing Pad

Trace and write the numbers.

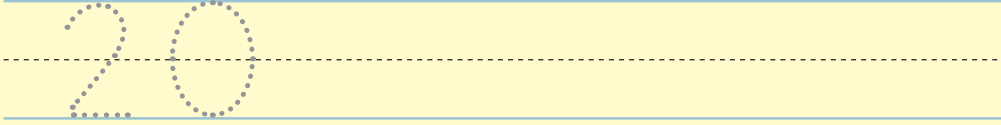
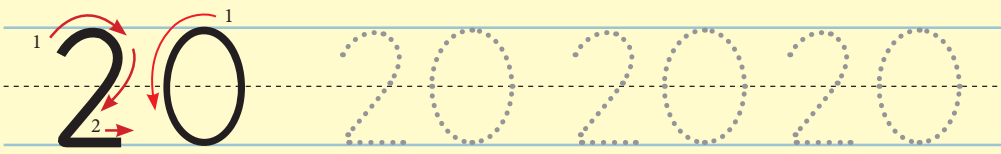
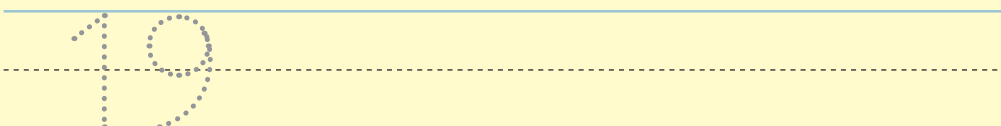
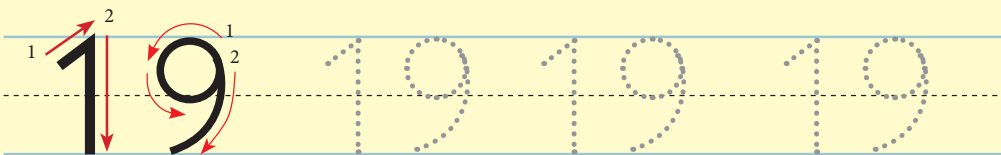
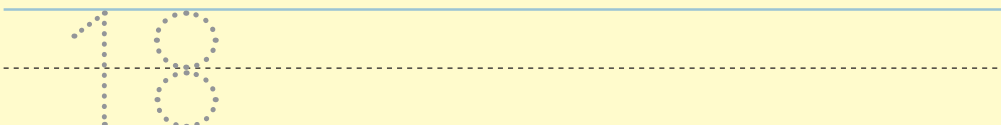
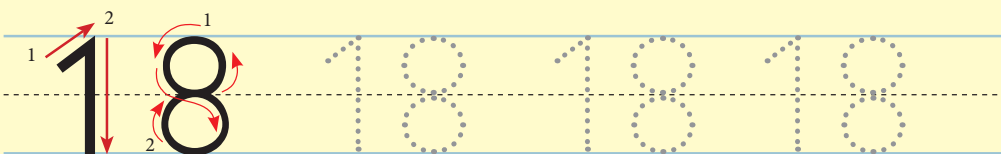
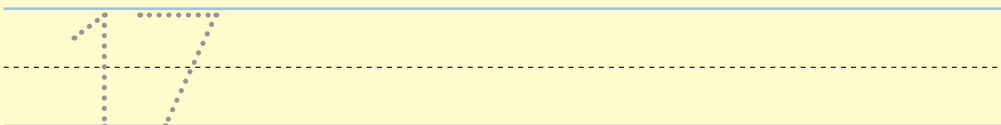
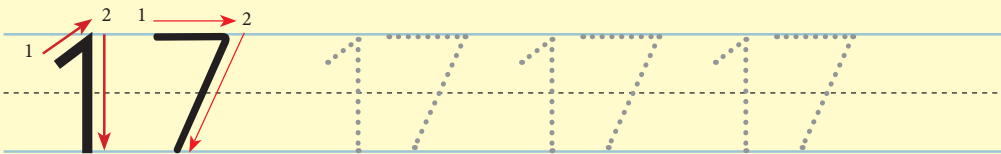

Practice

Number the seats from 10 to 20.

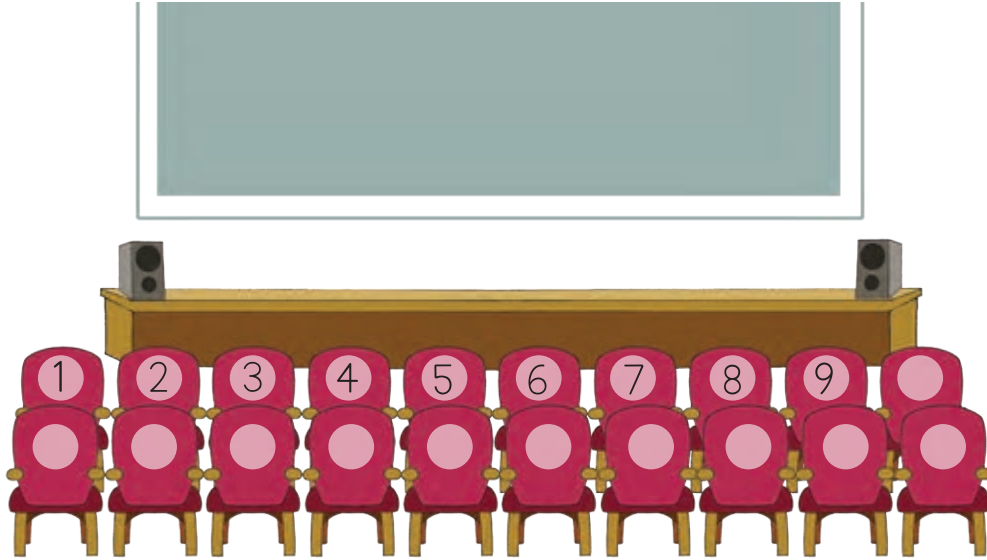

15  Listen and write.



A	<hr/> <hr/> <hr/>	<hr/> <hr/> <hr/>	<hr/> <hr/> <hr/>
B	<hr/> <hr/> <hr/>	<hr/> <hr/> <hr/>	<hr/> <hr/> <hr/>
C	<hr/> <hr/> <hr/>	<hr/> <hr/> <hr/>	<hr/> <hr/> <hr/>
D	<hr/> <hr/> <hr/>		

Self - Check

Check (✓) your learning.

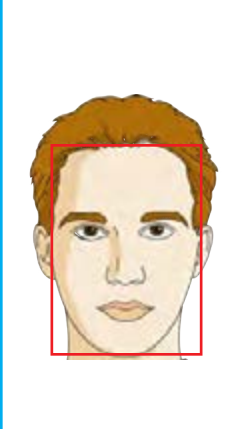
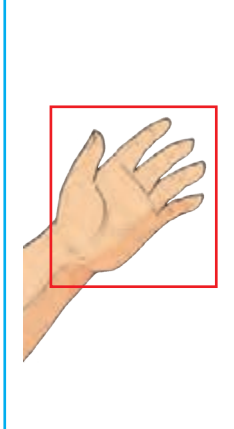
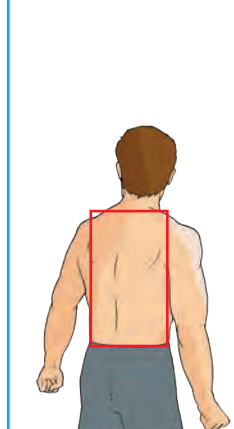
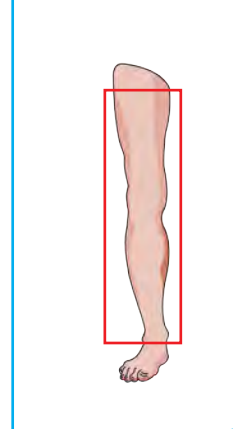
1. Vocabulary

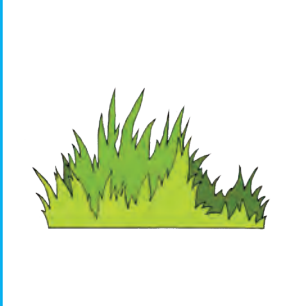
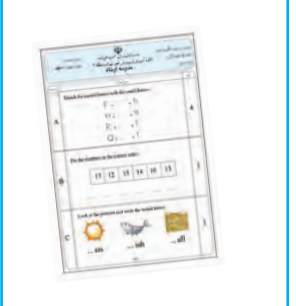
2. Letters

G g	Q q

3. Numbers

17	18	19	20













Review 1

A a B b C c D d E e F f G g H h I i



J j K k L l M m N n O o P p Q q

R r S s T t U u V v W w X x Y y Z z

1  Listen and choose the correct picture.

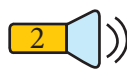
1			
2			
3			
4			

2  Listen and number the pictures.

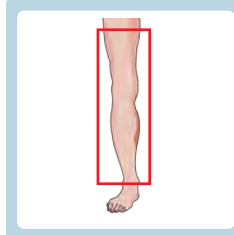
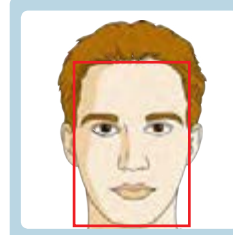
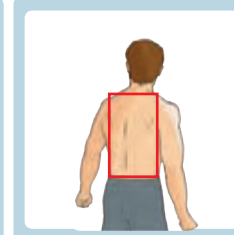
				
--	--	--	---	--

Match the capital letters with the small letters.

R .	. g
F .	. q
G .	. r
Q .	. l
L .	. f

Circle the initial letters.

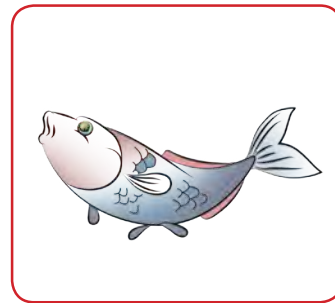
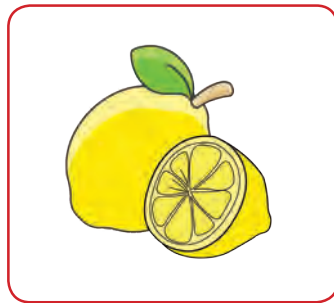

g / l / r

f / r / k

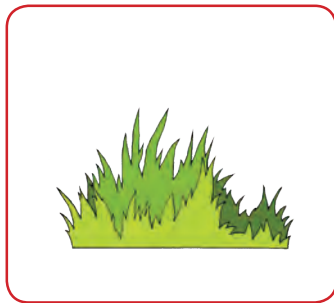

q / l / g

f / r / k

Find and circle the letters “g” and “r”.

bag key gift fish

kite robot lamp rain

3  Listen and circle the letters in each word.

1. fire

gift

fish

2. key

lamp

kite

3. quiz

grass

Quran

4. rain

green

robot

Look and write the missing letters.



fi...e



...amp



...ite



gi...t

4  Listen and write the missing letters.

1. ... emon

2. ... ey

3. ... rass

4. ... obot

Circle number 11, 14 and 19.

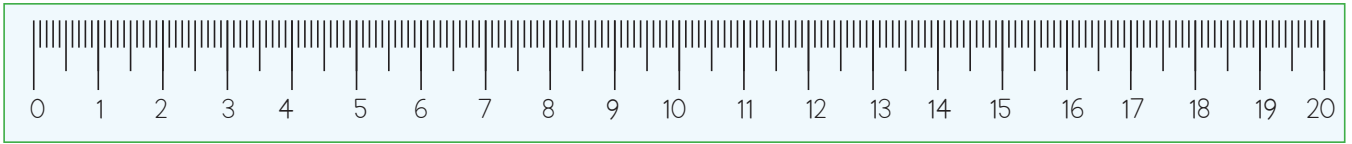

Put the numbers from 1 to 20 to complete the calendar below.



Pair work

Greet your friend and introduce your classmate to him/her.

Lesson 4

The Weather



The Weather of Iran

1  Listen.









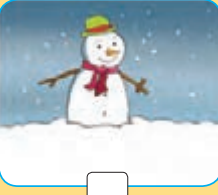

2  Listen and repeat.

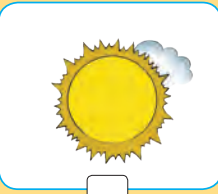
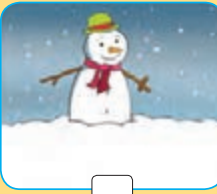

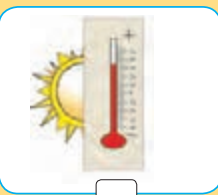
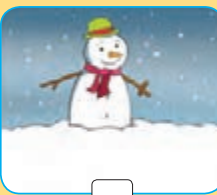
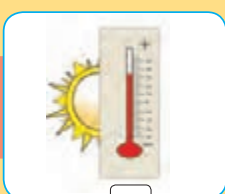
Practice

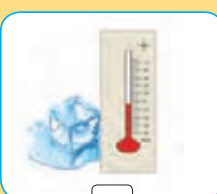
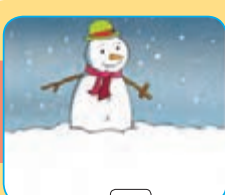
3  Listen and choose the correct picture.

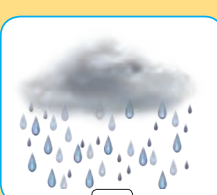
1	 <input type="checkbox"/>	 <input type="checkbox"/>	 <input type="checkbox"/>
2	 <input type="checkbox"/>	 <input type="checkbox"/>	 <input type="checkbox"/>
3	 <input type="checkbox"/>	 <input type="checkbox"/>	 <input type="checkbox"/>
4	 <input type="checkbox"/>	 <input type="checkbox"/>	 <input type="checkbox"/>
5	 <input type="checkbox"/>	 <input type="checkbox"/>	 <input type="checkbox"/>

4  Listen and check the correct answer.

1.

Yes
No

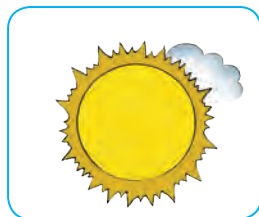

2.

Yes
No



5  Listen and check.

	Yes	No
1 	<input type="checkbox"/>	<input type="checkbox"/>
2 	<input type="checkbox"/>	<input type="checkbox"/>
3 	<input type="checkbox"/>	<input type="checkbox"/>
4 	<input type="checkbox"/>	<input type="checkbox"/>
5 	<input type="checkbox"/>	<input type="checkbox"/>



Pair work

Point to each picture and ask your friend to name it.



Letters: S s & Y y



6 Listen and repeat.

S s Y y

7 Listen and repeat.



sun

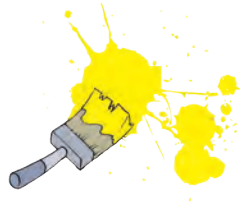

yellow



soup



yard

8 Listen again and point to the pictures above.

Sound out the letters in the words below.

“S” for



“Y” for



“S” for



“Y” for



9 Listen and chant.

It's the sun; “s”, “s”, sun.
It's soup; “s”, “s”, soup.
It's yellow; “y”, “y”, yellow.
It's a yard; “y”, “y”, yard.

Practice

10  Listen and choose the correct picture.

1

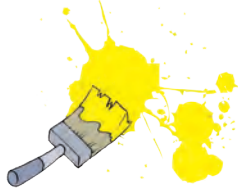

2



3



4



11  Listen and circle.



s / y



s / y

12  Listen and circle the initial letters.

- | | | |
|---|------|--------|
| 1 | sun | yellow |
| 2 | soup | yard |

Match the pictures with the initial letters.



y

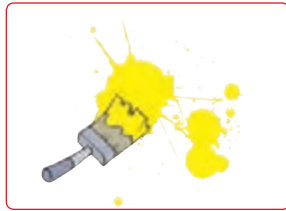

s

Read aloud.

S s Y y



Pair work

Point to each picture and ask your friend to name it.







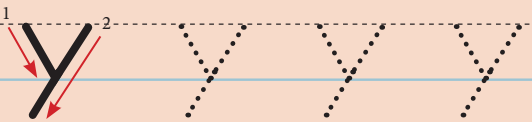
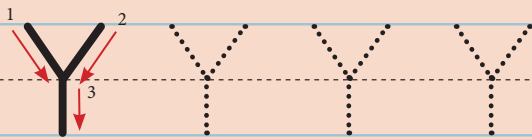
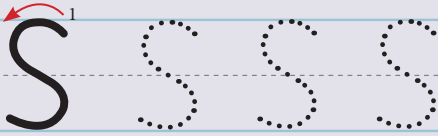





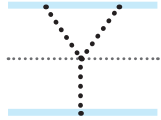

Writing Pad

Trace and write the letters.



Practice

13  Listen and trace.

1			
2			
3			
4			

14  Listen and write the missing letters.

			
1. ...oup	2. ...ard	3. ...un	4. ...ellow

Look at the pictures and write the initial letters.

 _____

 _____

Numbers: 21 - 30

15  Listen and repeat.

2022 CALENDAR

September

				1	2	3
4	5	6	7	8	9	10
11	12	13	14	15	16	17
18	19	20	21	22	23	24
25	26	27	28	29	30	



Practice

Circle numbers 21 to 30.

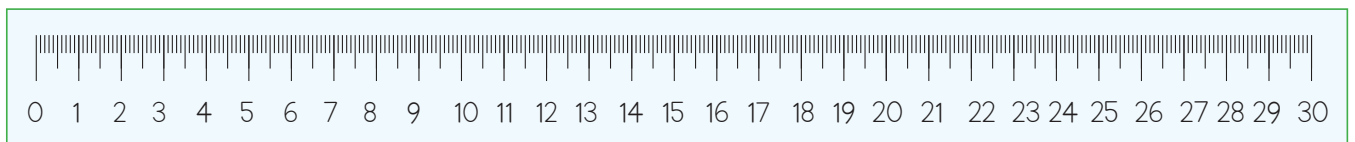



Pair work

Point to each number and ask your friend to read it.

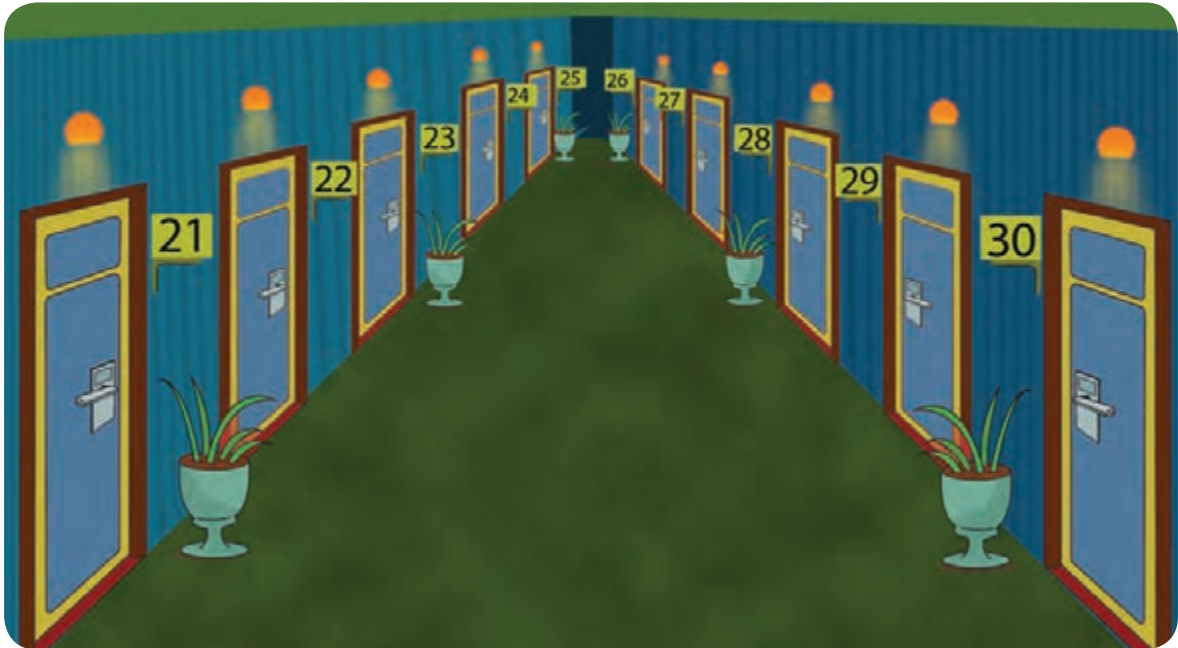

Join the numbers from 21 to 30 and name the picture.

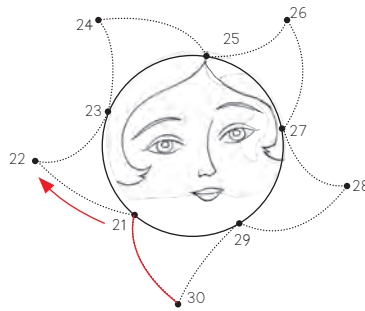

Pair work

Point to each picture and ask your friend to read the number.

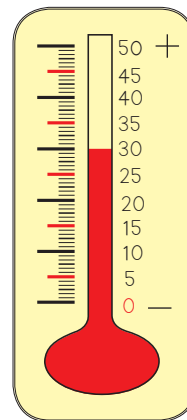
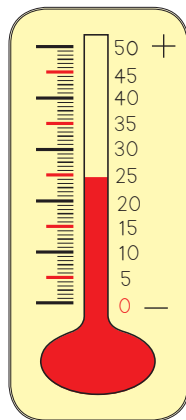

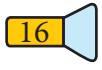





Listen and write.





A	<hr/> <hr/> <hr/>	<hr/> <hr/> <hr/>	<hr/> <hr/> <hr/>
B	<hr/> <hr/> <hr/>	<hr/> <hr/> <hr/>	<hr/> <hr/> <hr/>
C	<hr/> <hr/> <hr/>	<hr/> <hr/> <hr/>	<hr/> <hr/> <hr/>
D	<hr/> <hr/> <hr/>		

Self - Check

Check (✓) your learning.

1. Vocabulary

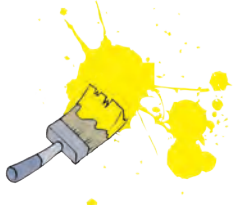
2. Letters

S s	Y y

3. Numbers

21	22	23	24	25	26	27	28	29	30

Lesson 5

Commands



Do's and Don'ts

1  Listen.

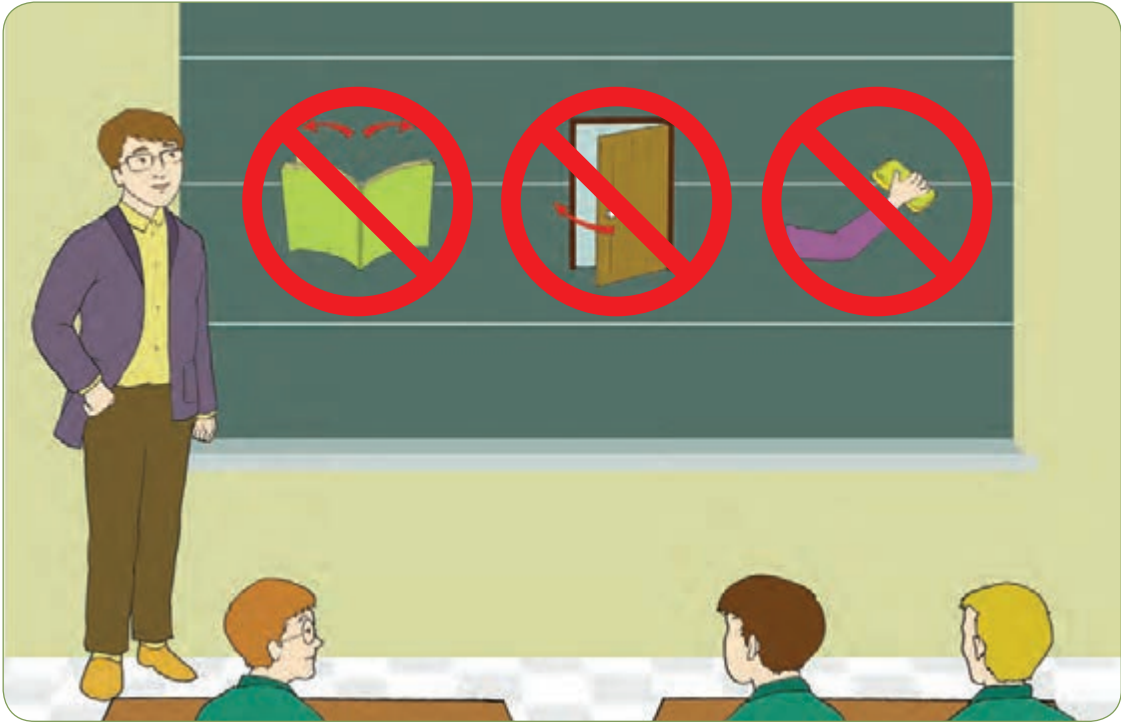

2  Listen and repeat.



Don't open your book.



Don't close the door.



Don't clean the board.

Practice

3 Listen and choose the correct picture.

1



2



3



4



4 Listen and number the commands.



...



...



...



Pair work

Point to each picture and ask your friend to give the command.

1

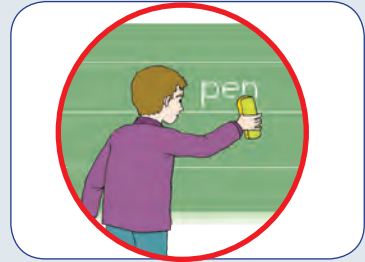

2



Letters: W w & X x



5 Listen and repeat.

W w X x

6 Listen and repeat.

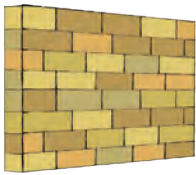

wall



box



window



taxi

7 Listen again and point to the pictures above.

Sound out the letters in the words below.

“X” for



“W” for

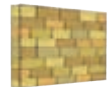

“X” for



“W” for



8 Listen and chant.

It's a wall; “w”, “w”, wall.

It's a window; “w”, “w”, window.

It's a box; “x”, “x”, box.

It's a taxi; “x”, “x”, taxi.

Practice

9  Listen and choose the correct picture.

1



2

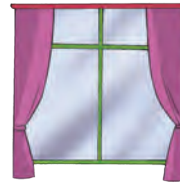
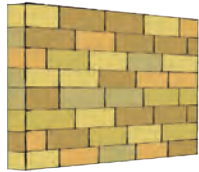

3



4



10  Listen and circle.



x / w



x / w

Look at each picture and check the correct letter.

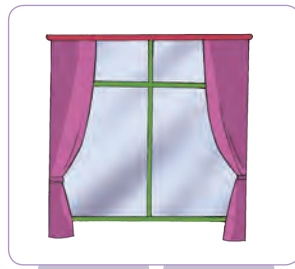

W

X

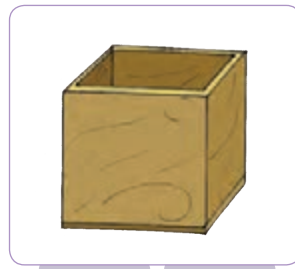

W

X

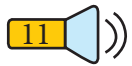

Listen and circle the letters.

1



W

X



W

X

2



W

X



W

X

Read aloud.

W w X x



Pair work

Point to each picture and ask your friend to name it.

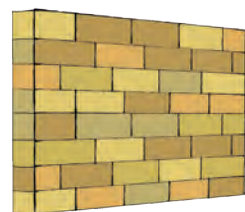

Writing Pad

Trace and write the letters.

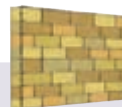

Tracing practice for uppercase letter W. The first row shows a solid black 'W' with red arrows and numbers 1, 2, 3, and 4 indicating the stroke order: 1 (down-left), 2 (up-right), 3 (down-left), 4 (up-right). This is followed by three dotted 'W's for tracing on a set of three horizontal lines (top, middle-dashed, bottom).

Blank handwriting lines for practicing uppercase letter W.

Tracing practice for lowercase letter w. The first row shows a solid black 'w' with red arrows and numbers 1, 2, 3, and 4 indicating the stroke order: 1 (down-left), 2 (up-right), 3 (down-left), 4 (up-right). This is followed by three dotted 'w's for tracing on a set of three horizontal lines (top, middle-dashed, bottom).

Blank handwriting lines for practicing lowercase letter w.



Tracing practice for uppercase letter X. The first row shows a solid black 'X' with red arrows and numbers 1 and 2 indicating the stroke order: 1 (down-left), 2 (down-right). This is followed by three dotted 'X's for tracing on a set of three horizontal lines (top, middle-dashed, bottom).











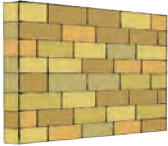

Blank handwriting lines for practicing uppercase letter X.

Tracing practice for lowercase letter x. The first row shows a solid black 'x' with red arrows and numbers 1 and 2 indicating the stroke order: 1 (down-left), 2 (down-right). This is followed by three dotted 'x's for tracing on a set of three horizontal lines (top, middle-dashed, bottom).



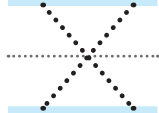

Blank handwriting lines for practicing lowercase letter x.

Practice

12  Listen and trace.

1			
2			
3			
4			

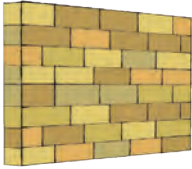
13  Listen and write the missing letters.

			
1. ...indow	2. ta...i	3. ...all	4. bo...

Look at the pictures and write "w" or "x".

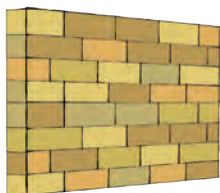



Numbers: 31-40

14  Listen and repeat.

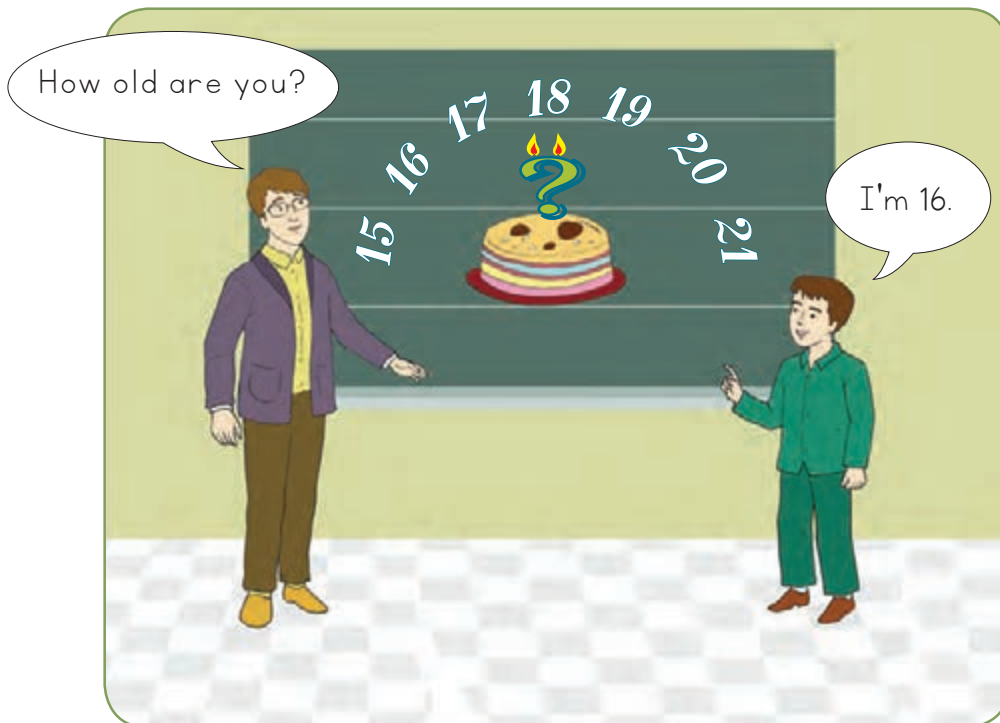
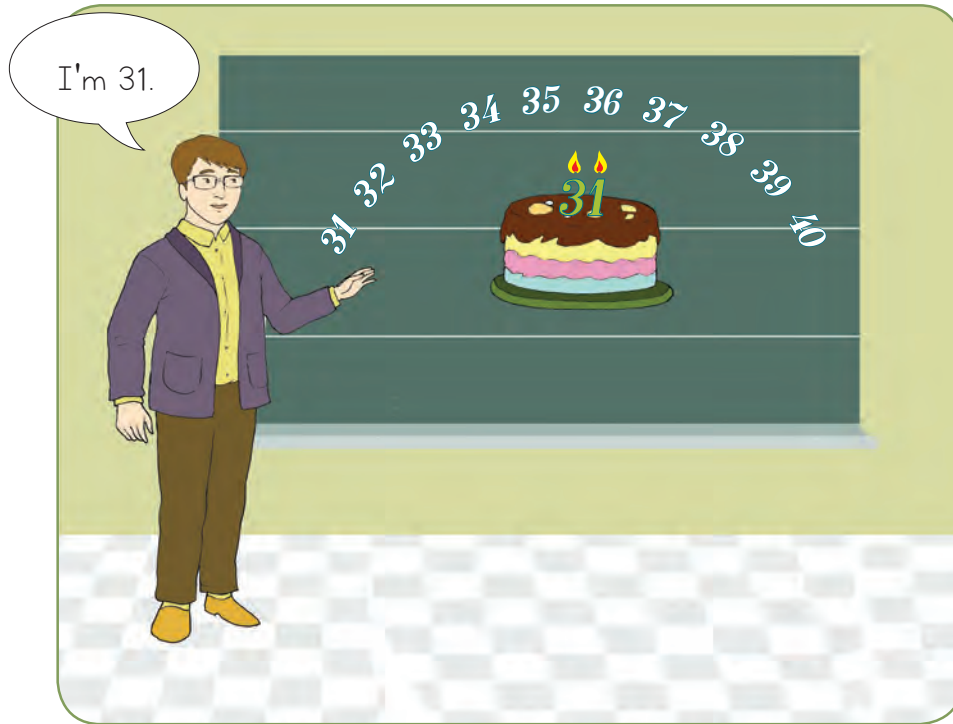

Practice

15  Listen and circle.

1. 32 34 40
2. 33 35 37
3. 31 36 33
4. 35 39 40



Pair work

Point to each picture and ask your friend to read the number.



16  Listen and write.

A	<hr/> <hr/>	<hr/> <hr/>	<hr/> <hr/>
B	<hr/> <hr/>	<hr/> <hr/>	<hr/> <hr/>
C	<hr/> <hr/>	<hr/> <hr/>	<hr/> <hr/>
D	<hr/> <hr/>		



Pair work

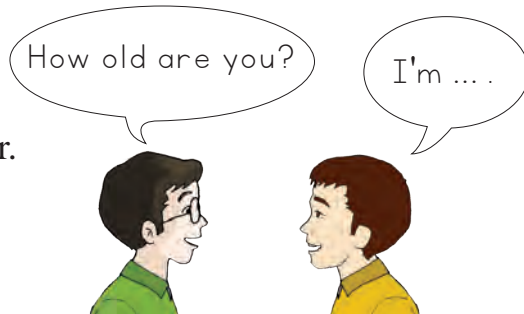

Ask and answer.







Self - Check

Check (✓) your learning.

1. Commands

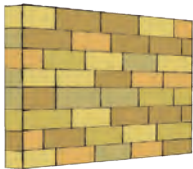
2. Vocabulary

3. Letters

Ww	Xx

4. Numbers

31	32	33	34	35	36	37	38	39	40

Lesson 6

My House

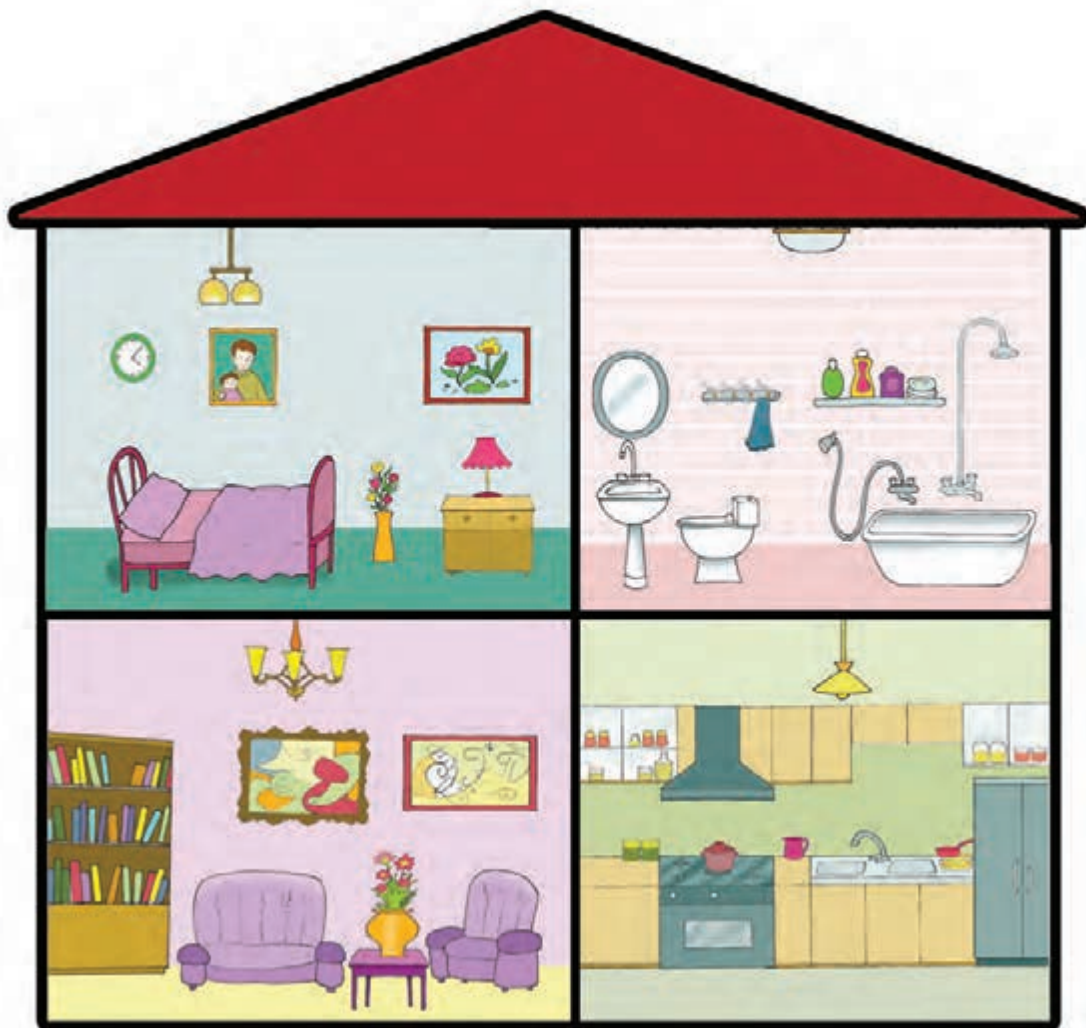

Parts of a House

1 Listen.



bedroom



bathroom



kitchen

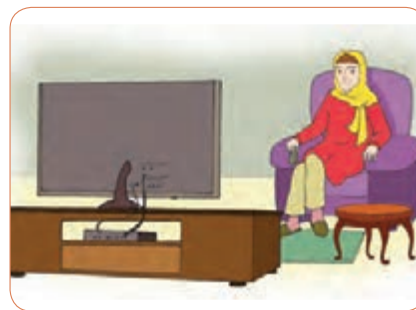

living room

2 Listen and repeat.

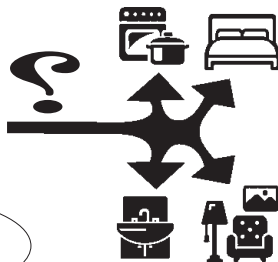

Mom is in the kitchen.



Dad is in the bathroom.

3 Look at the pictures on the top. Listen and repeat.

Practice

4  Listen and check the correct answer.

1.

Yes
No



2.

Yes
No



5  Listen and check.

		Yes	No
1			
2			
3			
4			

6  Listen and choose the correct picture.

1



2



3



4



 Listen and number the pictures.



...



...



...



...



Pair work

Point to each picture and ask your friend to name it.

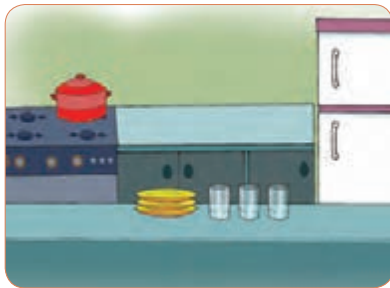

Reading & Writing



Letter Hunt

Tick the small letters.

o	a	T
H	c	h
A	t	i



Word Search

Look at the pictures and find the words in the tables below.

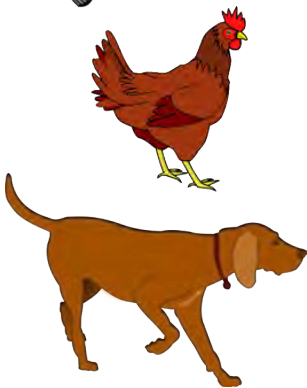

h	e	n
p	e	n

d	o	g
b	a	g



c	a
a	n
t	t



Word Completion

Write the missing letters to complete the words.



h	t
---	-------	---



c	a
---	---	-------



Puzzle

Look at the pictures and complete the puzzles.

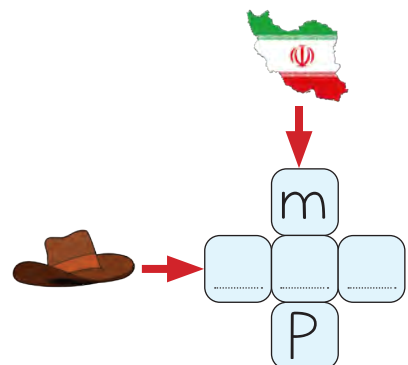
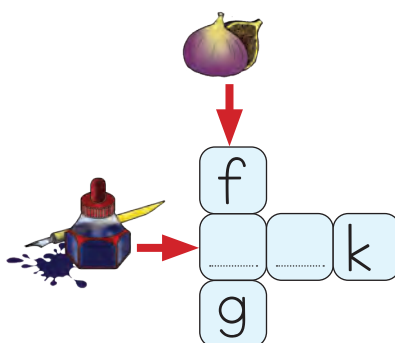
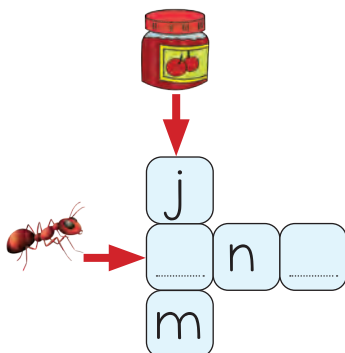

Writing Pad

Practice writing the following words.

ant



cat



hat



map



jam



ink



fig



Numbers: 41-50

8  Listen and repeat.

41 42 43 44 45 46 47 48 49 50

9  Listen and repeat the dialogue.



10  Listen and choose the correct picture.

1			
2			
3			
4			



Listen and write.

A	<hr/> <hr/>	<hr/> <hr/>	<hr/> <hr/>
B	<hr/> <hr/>	<hr/> <hr/>	<hr/> <hr/>
C	<hr/> <hr/>	<hr/> <hr/>	<hr/> <hr/>
D	<hr/> <hr/>		



Pair work

Point to each number and ask your friend to read it.

41 42 43 44 45 46 47 48 49 50

Self - Check

Check (✓) your learning.

1. Vocabulary

2. Reading

ant	cat	hat	map	jam	ink	fig

3. Numbers

41	42	43	44	45	46	47	48	49	50





Review 2

A a B b C c D d E e F f G g H h I i

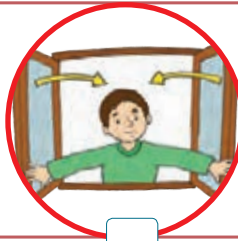

J j K k L l M m N n O o P p Q q

R r S s T t U u V v W w X x Y y Z z

1 Listen and check the correct picture.

1	 <input type="checkbox"/>	 <input type="checkbox"/>
2	 <input type="checkbox"/>	 <input type="checkbox"/>
3	 <input type="checkbox"/>	 <input type="checkbox"/>

2 Listen and check.

	Yes	No
1		
2		
3		

3  Number the pictures as you listen.

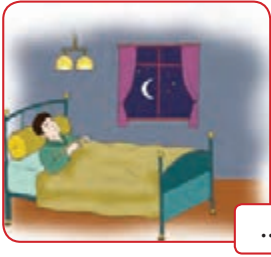

...



...



...



...

Match the capital letters with the small letters.

S	•	•	w
Y	•	•	s
W	•	•	x
X	•	•	y

Look and circle the initial letters.

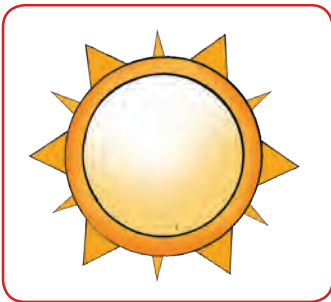

x / y / s



w / y / s



w / x / y

Find and circle the letters "s" and "x".

box

wall

robot

taxi

yard

soup

yellow

sun

4  Listen and circle the letters in each word.

- | | | |
|-----------|--------|--------|
| 1. yellow | wall | window |
| 2. taxi | sun | box |
| 3. soup | fire | sun |
| 4. yard | yellow | window |

Look and write the missing letters.



bo...



...oup

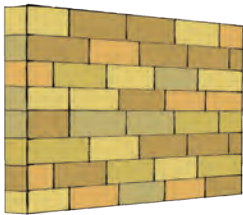

...all

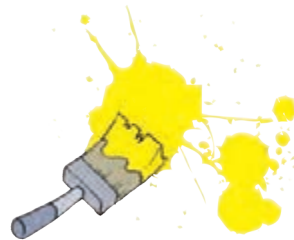

...ellow

5  Listen and write the missing letters.

- | | |
|-----------|-------------|
| 1. ...ard | 2. ...un |
| 3. ta...i | 4. ...indow |



Pair work

Point to each word and ask your friend to read it.

1. hat 2. cat 3. fig 4. jam 5. ink 6. map 7. ant

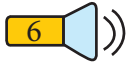

Listen and check.

		Yes	No
1			
2			
3			
4			



Pair work

Point to each number and ask your friend to read it.

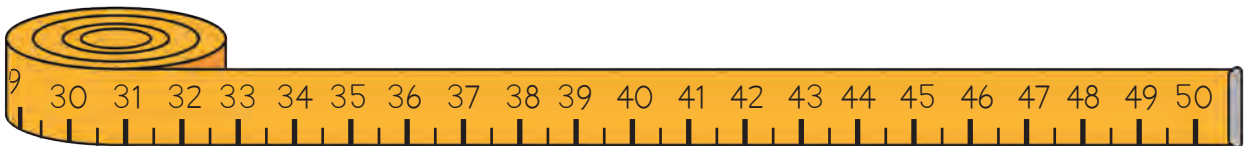

Lesson 7

Public Places



Places to Go

1 Listen.

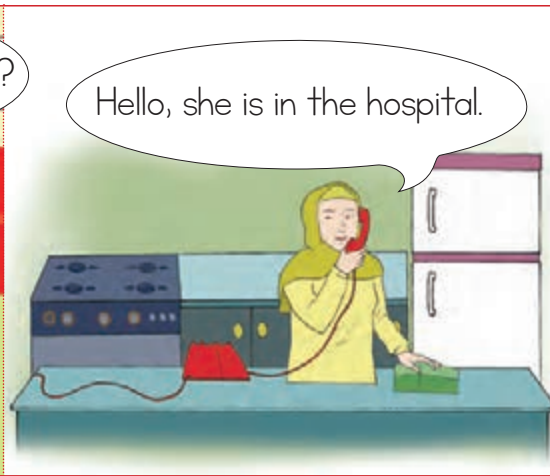

4



5



2 Listen and repeat.

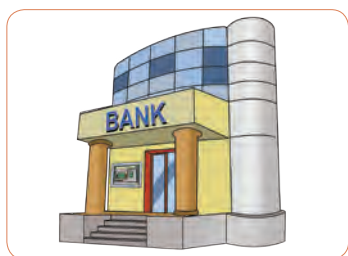

bank



supermarket



mosque



hospital



school

Practice

3  Listen and check.

Yes

No

1



2



3



4



5



4 Listen and choose the correct picture.

1



2



3



4



5



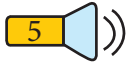

Listen and number the pictures.



...



...



...



...



...

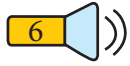

Listen and number the pictures. Then name each.



...



...



...

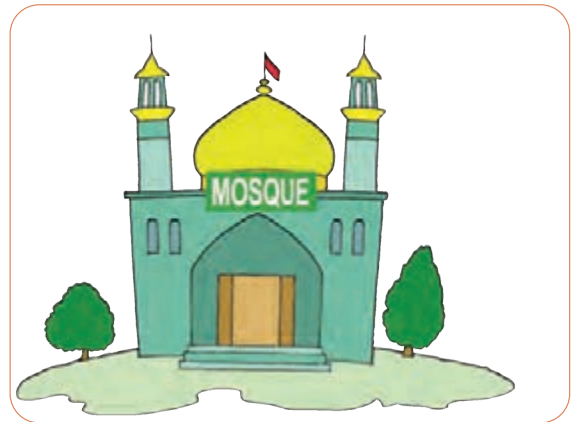

...

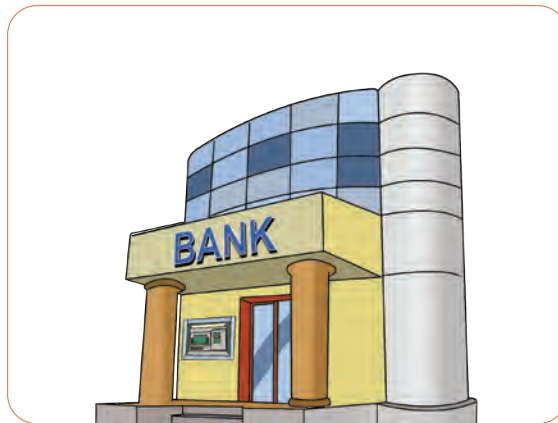

...

Reading & Writing



Letter Hunt

Tick the small letters.

U	e	b
D	B	j
u	J	N



Word Search

Look at the pictures and find the words in the tables below.



m	a	p
j	a	m



e	b
g	e
g	d



Word Completion

Write the missing letters to complete the words.



h e _____



i n _____



Puzzle

Look at the pictures and complete the puzzles.

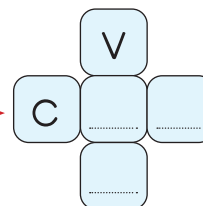
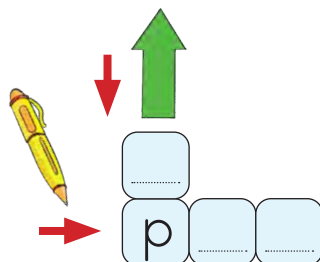
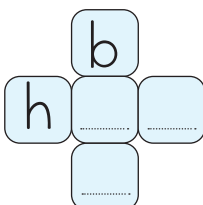

Writing Pad

Practice writing the following words.

van



hen



pen



bed



ink



up



Numbers: 51-60

7  Listen and repeat.

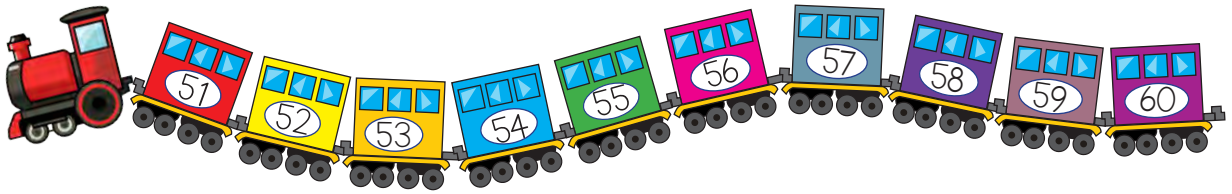

8  Listen and circle.

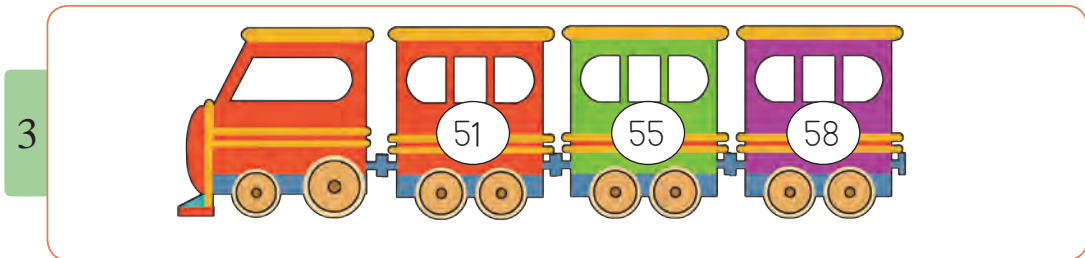
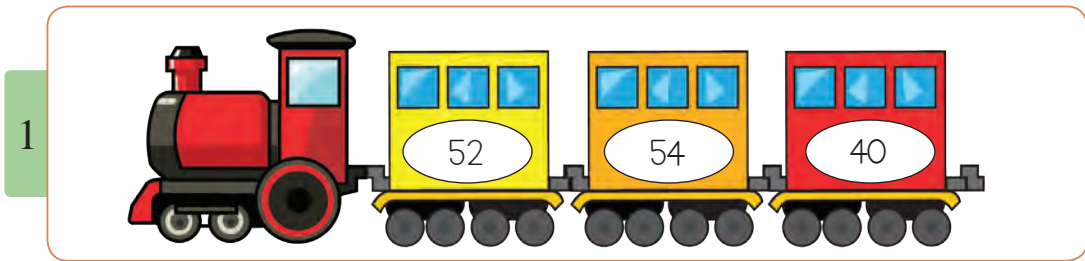

Join the numbers to complete the picture.

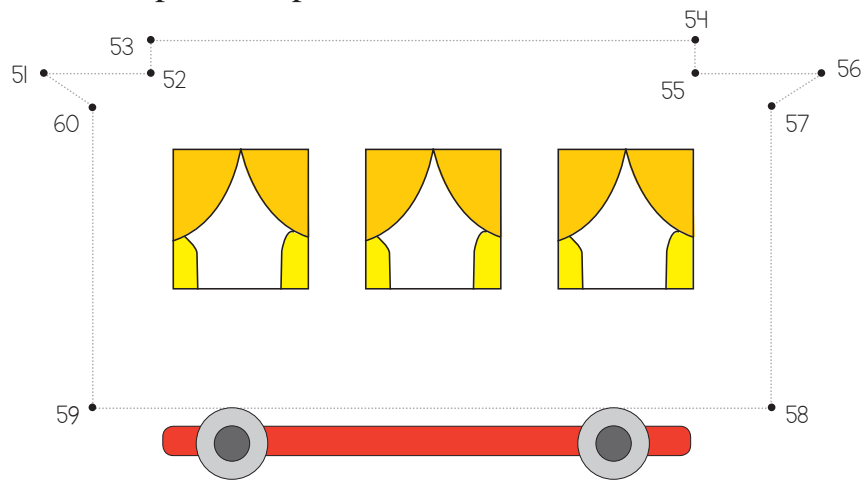

9 Listen and write.

A	<hr/> <hr/>	<hr/> <hr/>	<hr/> <hr/>
B	<hr/> <hr/>	<hr/> <hr/>	<hr/> <hr/>
C	<hr/> <hr/>	<hr/> <hr/>	<hr/> <hr/>
D	<hr/> <hr/>		



Pair work



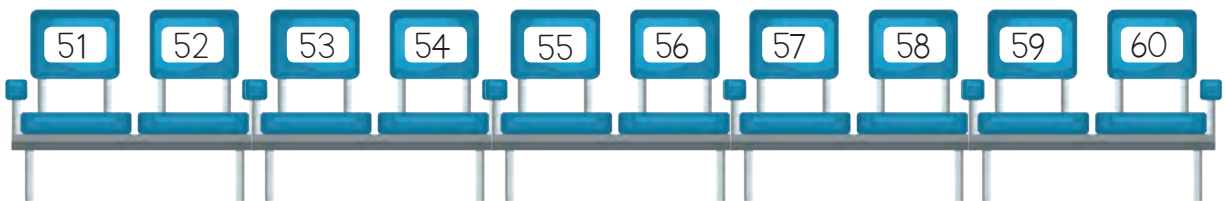

Point to each number and ask your friend to read it.



Self - Check

Check (✓) your learning.

1. Vocabulary

2. Reading

van	hen	pen	bed	ink	up

3. Numbers

51	52	53	54	55	56	57	58	59	60

Lesson 8

My Classroom

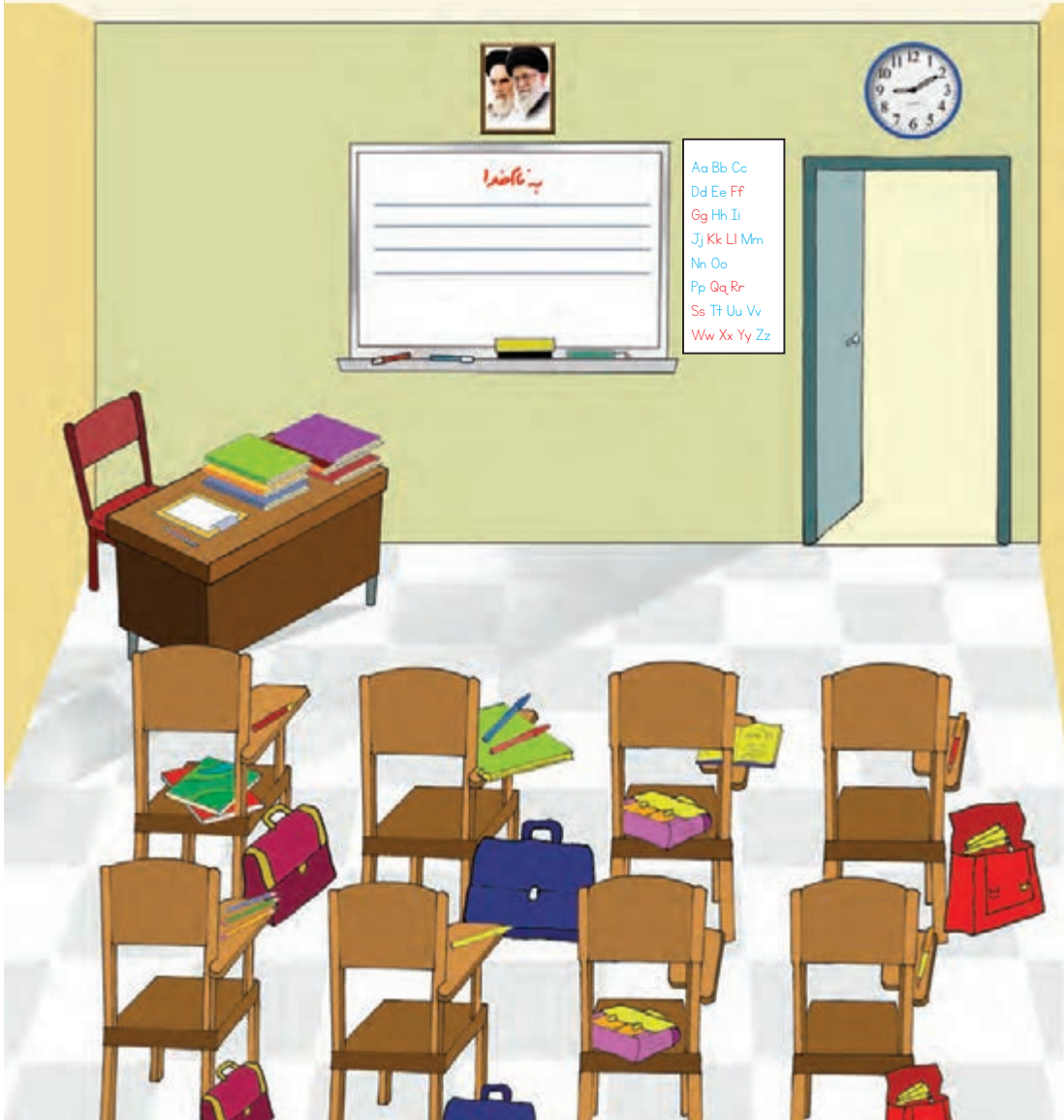

School Objects

1 Listen.



How many pens?

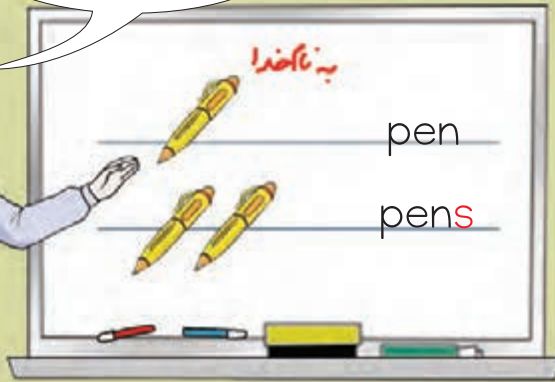

Aa Bb Cc
Dd Ee Ff
Gg Hh Ii
Jj Kk Ll Mm
Nn Oo
Pp Qq Rr
Ss Tt Uu Vv
Ww Xx Yy Zz



2 Listen and repeat.



pens



pencils



books

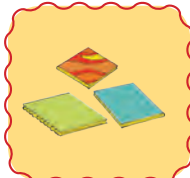

notebooks



chairs



bags

Practice

3 Listen and choose the correct picture.

1

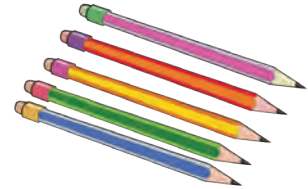
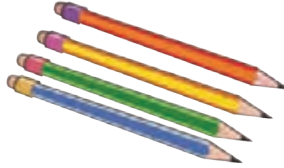
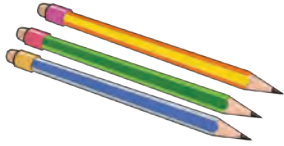

2

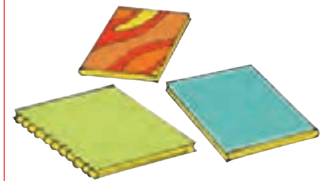
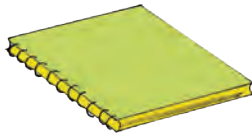
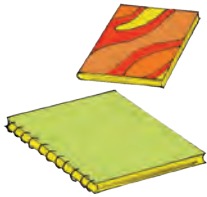

3



4



Practice

4  Listen and answer.

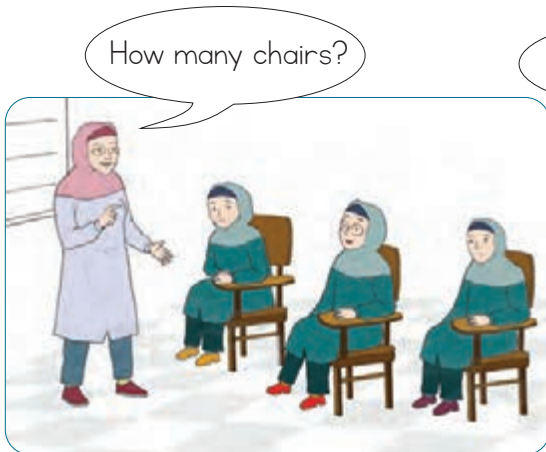

Pair work

Point to each picture and ask your friend to tell the number of the items.

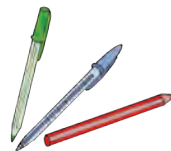
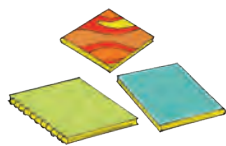

Reading & Writing



Letter Hunt

Tick the small letters.

M	q	v
I	Z	m
z	Q	L



Word Search

Look at the pictures and find the words in the tables below.



c	a	t
m	a	p

z	h
o	a
o	t

v	a	n
a	n	t



Word Completion

Write the missing letters to complete the words.

b a ...

p a ... k

l a m ...



Puzzle

Look at the pictures and complete the puzzles.

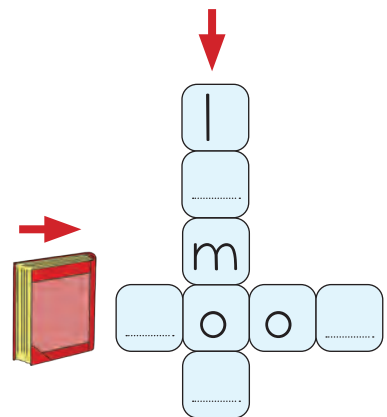
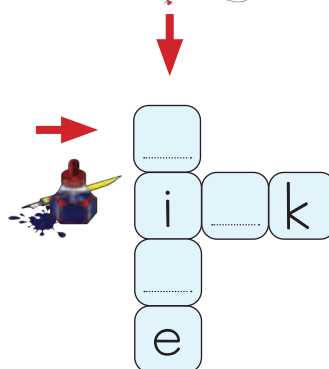
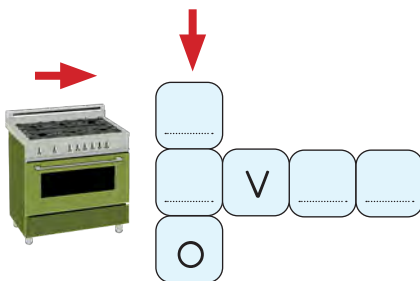
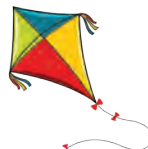

Writing Pad

Practice writing the following words.

bag



lamp



lemon



zoo

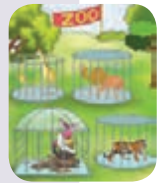

book



park



oven



Number Review: 0-30

Write the number of the letters.



.....



Pair work

Point to each watch and ask your friend to read it.







Listen and write.

A	<hr/> <hr/> <hr/>	<hr/> <hr/> <hr/>	<hr/> <hr/> <hr/>
B	<hr/> <hr/> <hr/>	<hr/> <hr/> <hr/>	<hr/> <hr/> <hr/>
C	<hr/> <hr/> <hr/>	<hr/> <hr/> <hr/>	<hr/> <hr/> <hr/>

Self - Check

Check (✓) your learning.

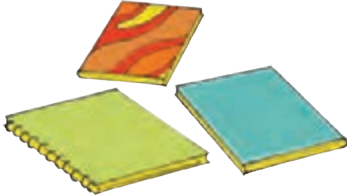
1. Vocabulary

2. Reading

bag	lamp	lemon	zoo	book	park	oven

3. Numbers

0	1	2	3	4	5	6	7	8	9	10	11	12	13	14	15
16	17	18	19	20	21	22	23	24	25	26	27	28	29	30	

Lesson 9

Colors



Colors

1  Listen.



2  Listen and repeat.



It's brown.

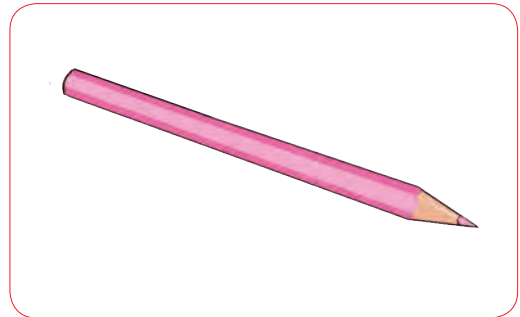

It's pink.

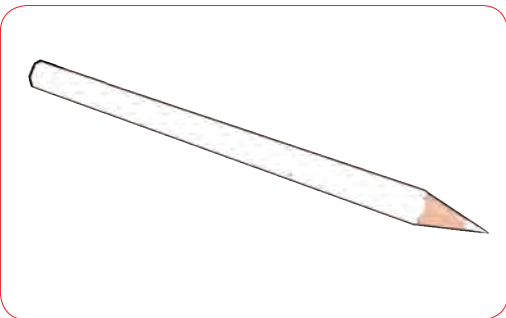

It's white.



It's black.



3  Listen and repeat.

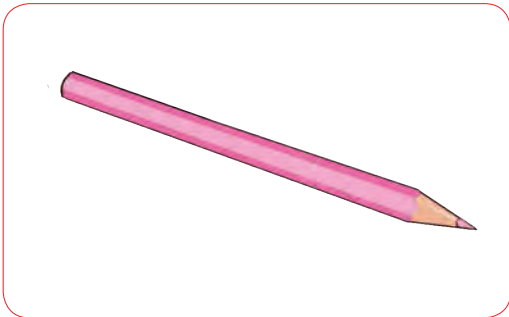

It's a pink pencil.



It's a brown pencil.



It's a black pencil.

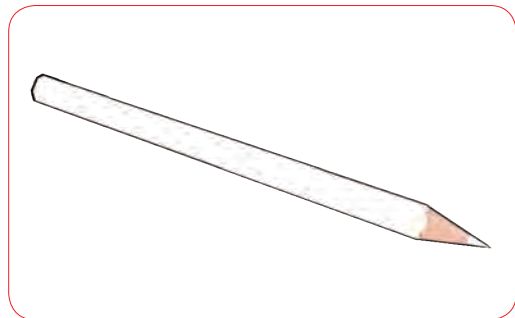

It's a white pencil.

4  Listen and repeat.



5  Listen and repeat.



It's pink.



It's brown.

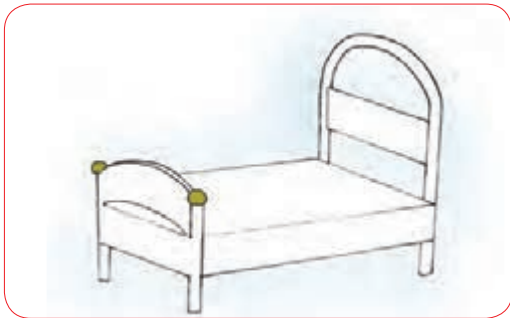

It's white.

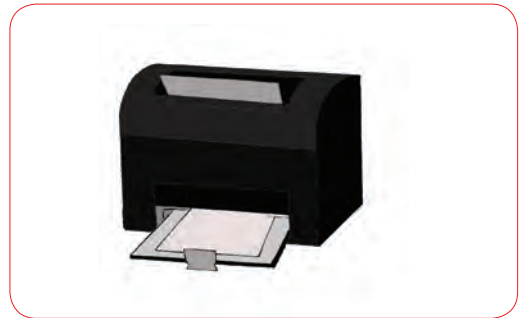

It's black.

Practice

6  Listen and choose the correct picture.

1



2



3

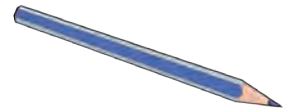
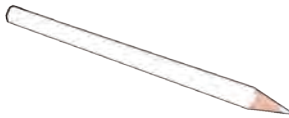

4





Listen and choose the correct picture.

1



2



3

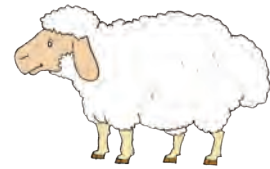
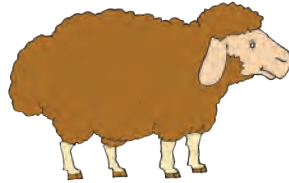
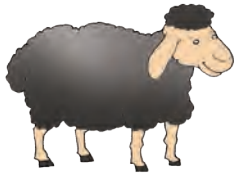



4



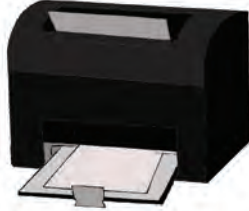

Listen and check.

Yes	No
-----	----

1			
2			
3			
4			



Pair work

Ask the students to talk about the color of the items in their bags using the pattern below.

What color is the

It's ...

Reading & Writing



Letter Hunt

Tick the small letters.

F	q	s
Y	R	w
x	S	G



Word Search

Look at the pictures and find the words in the tables below.

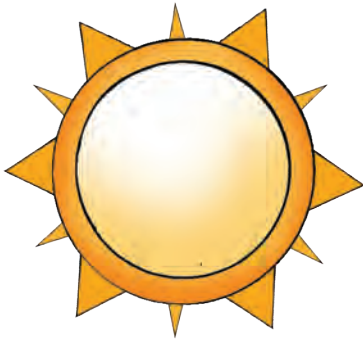

v	a	n
s	u	n

b	f
o	i
x	g

y	a	r	d
g	i	f	t



Word Completion

Write the missing letters to complete the words.

y a r ...

t a ... i

q u i ...

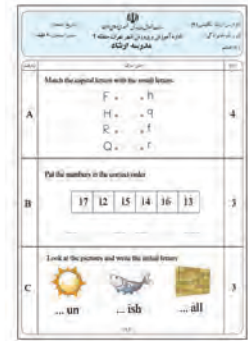

Puzzle

Look at the pictures and complete the puzzles.

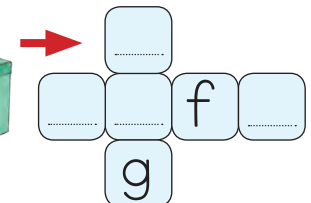
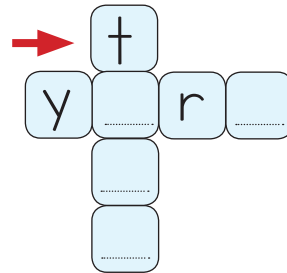
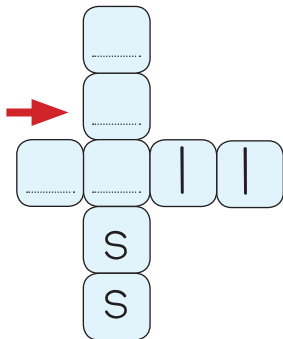
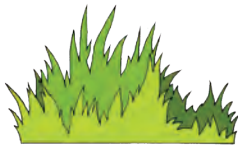

Writing Pad

Practice writing the following words.

box



sun



gift



quiz



taxi



grass



yard



wall

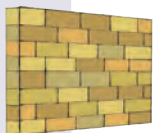

Number Review: 31-60

9  Listen and number the pictures.



Pair work

Point to each watch and ask your friend to read it.

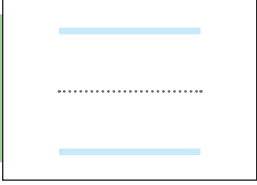
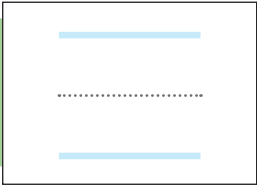

10  Listen and write.

A			
B			
C			



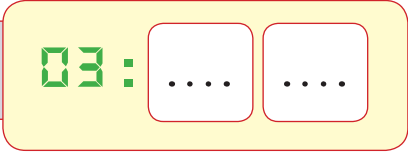
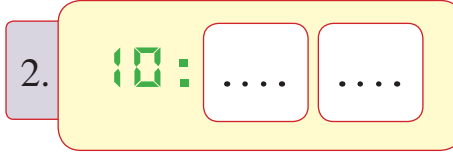
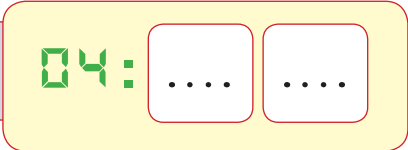
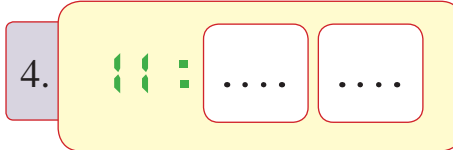

11  Listen and write the missing numbers.

1.		2.	
3.		4.	

Self - Check

Check (✓) your learning.

1. Vocabulary

2. Reading

box	sun	gift	quiz	taxi	grass	yard	wall

3. Numbers

31	32	33	34	35	36	37	38	39	40	41	42	43	44	45

46	47	48	49	50	51	52	53	54	55	56	57	58	59	60

Review 3

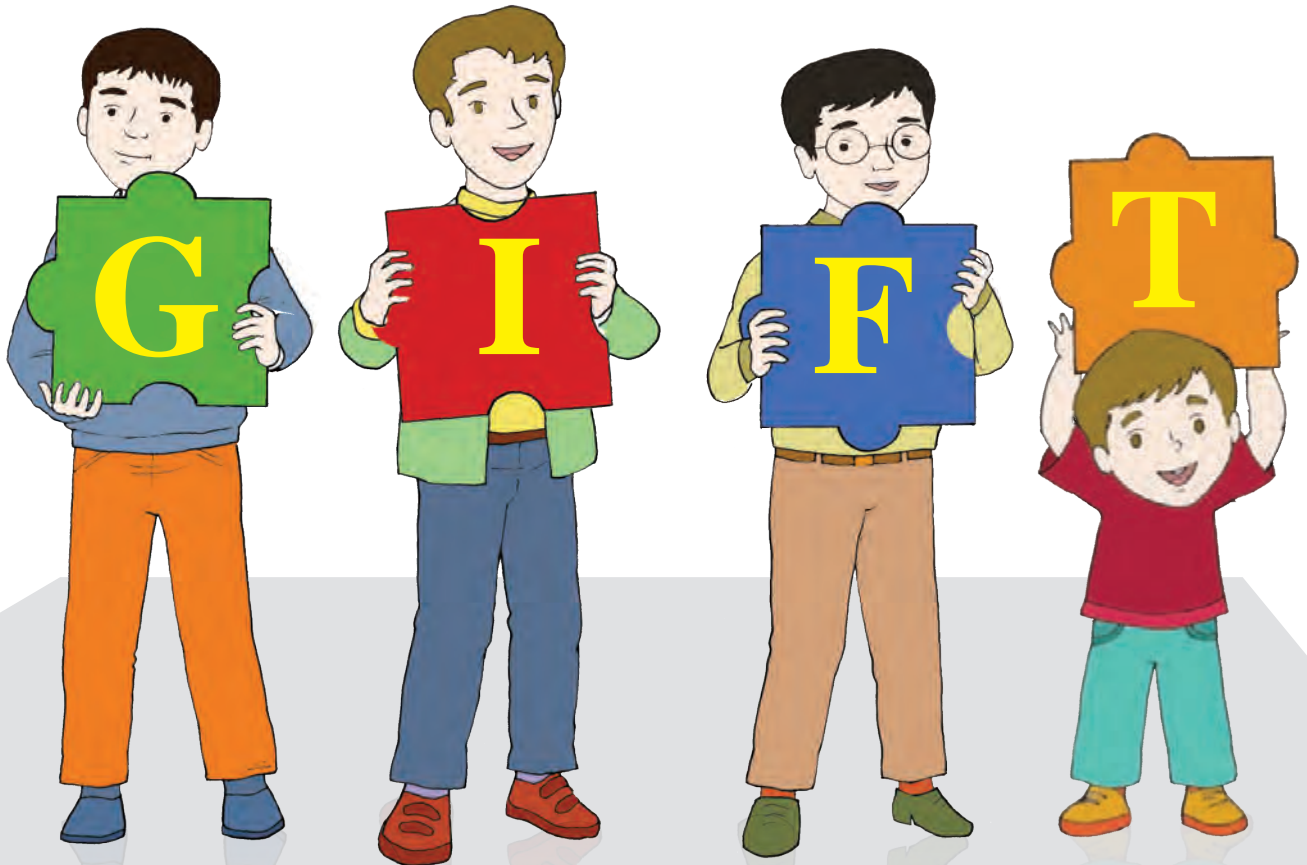

1 Listen and choose the correct picture.

1



2

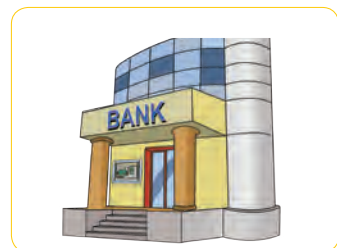

3





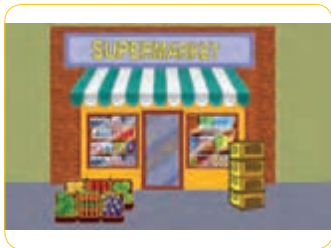

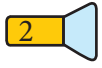
4





Listen and check.

Yes	No
-----	----

1			
2			
3			
4			

3 Listen and number the pictures.

					
...

Join the alphabets to complete the picture and name it.

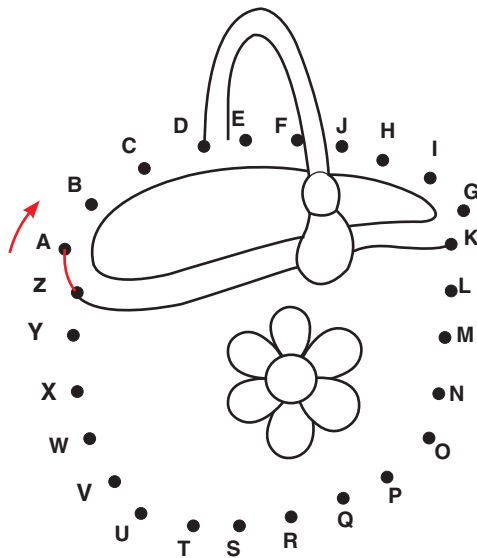

Count the capital letters. How many are they?

G	b	F	d
a	Q	e	q
t	h	r	H
M	p	R	E

.....

Look at the pictures and find the words in the tables below.

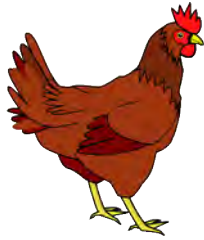

h	a	t
h	e	n



b	d
a	o
g	g



b	o	x
m	a	p



l	k
a	i
m	t
p	e



v	a	n
s	u	n



y	a	r	d
w	a	l	l

Write the missing letters.

j a ...



i n ...



h a ... d



g i ... t



4  Listen and write the missing letters.

1. de...k

2. le...

3. b...d

4. o...en

5. ya...d

6. l...mp

Look at the pictures and do the puzzles.

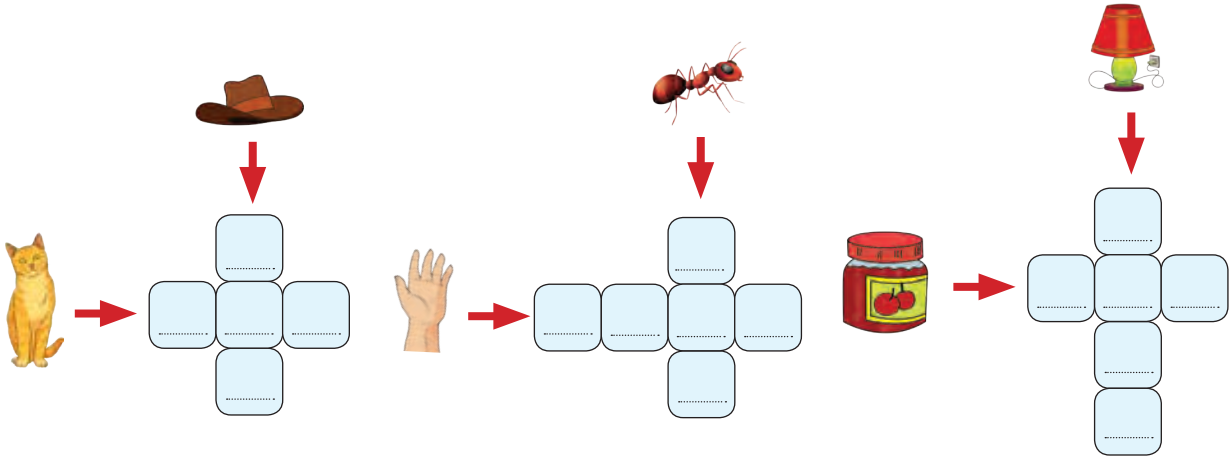

Pair work

Point to each word and ask your friend to read it.

1. fig

2. hot

3. cold

4. lamp

5. sun

6. ink

7. grass

8. leg

9. box

10. desk



Write down what you hear.

1.

Blank writing box with three horizontal lines (top, middle dotted, bottom).

2.

Blank writing box with three horizontal lines (top, middle dotted, bottom).

3.

Blank writing box with three horizontal lines (top, middle dotted, bottom).

4.

Blank writing box with three horizontal lines (top, middle dotted, bottom).



Pair work

Point to each watch and ask your friend to read it.

1.



2.



3.



4.



Photo Dictionary

Lesson 1

Mr. Ahmadi



Ms. Tavana



lemon



lamp



key



kite

Lesson 2



mom



dad



brother



sister



fish



fire



robot



rain

Lesson 3



head

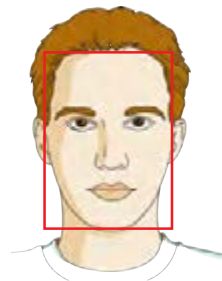

face

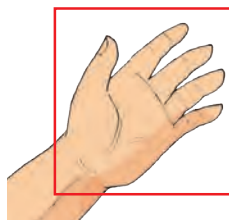

hand

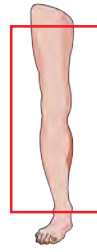

leg

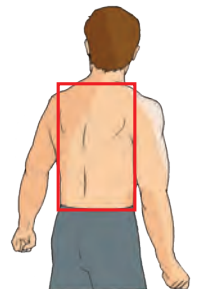

back



gift

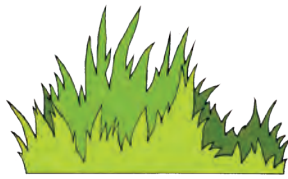

grass



quiz



(the) Quran

Lesson 4



hot

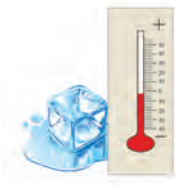

cold



sunny



rainy



snowy



sun



soup



yellow



yard

Lesson 5

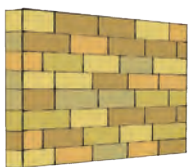

wall



window



box



taxi

Lesson 6



kitchen



bedroom



bathroom



living room

Lesson 7



school



mosque



bank



hospital



supermarket

Lesson 8



pencil



chair

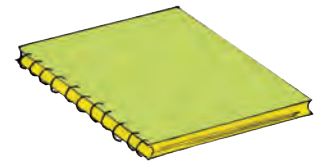

notebook

Lesson 9



black



white



pink



brown

Sentences



Good morning.
How are you?
Fine.



Bye.



This is Ms. Tavana.



This is Mr. Ahmadi.

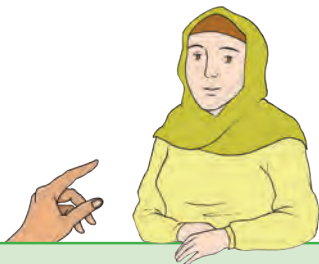

This is my mom.



This is my dad.



This is my brother.



This is my sister.

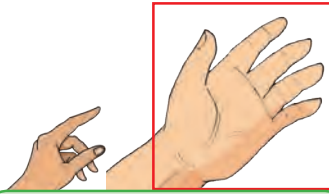

This is my hand.

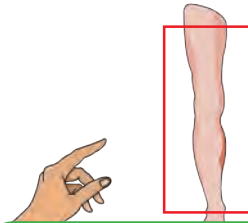

This is my leg.

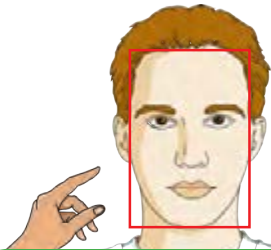

This is my face.



This is my head.

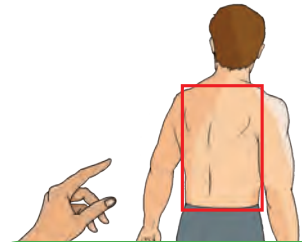

This is my back.



It is hot.

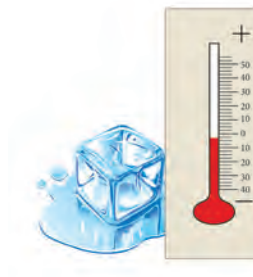

It is cold.



It is sunny.



It is rainy.



It is snowy.



Don't close the door.

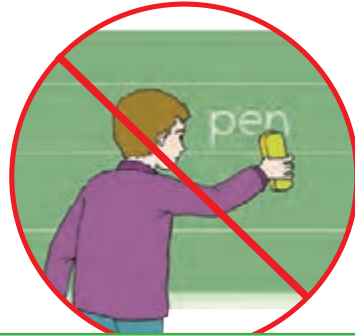

Don't clean the board.



Don't open your book.



He is 48.



She is 42.



How old are you?
I am 31.



This is the bedroom.



This is the kitchen.



This is the living room.



This is the bathroom.



He is in the living room



She is in the kitchen.



He is in the bathroom.



She is in the bedroom.



He is in the bank.



She is in the mosque.



She is in the school.



He is in the supermarket.



He is in the hospital.



It is brown.



It is black.



It is white.



It is pink.



It is a pink pencil.



It is a brown pencil.



It is a black pencil.



It is a white pencil.

List of Instructions

Ask and answer.	سؤال کنید و پاسخ دهید.
Ask the students to greet each other using the pattern above.	از دانش آموزان بخواهید با استفاده از الگوی بالا با یکدیگر سلام و احوال‌پرسی کنند.
Ask the students to talk about the color of the items in their bags using the pattern below.	از دانش آموزان بخواهید با استفاده از الگوی زیر درباره رنگ وسایل داخل کیفشان صحبت کنند.
Check (✓) your learning.	آنچه یاد گرفته‌اید را علامت بزنید.
Circle number 11, 12 and 13.	دور اعداد ۱۱، ۱۲ و ۱۳ دایره بکشید.
Circle number 11, 14 and 19.	دور اعداد ۱۱، ۱۴ و ۱۹ دایره بکشید.
Circle number 14, 15 and 16.	دور اعداد ۱۴، ۱۵ و ۱۶ دایره بکشید.
Circle number 17, 18, 19 and 20.	دور اعداد ۱۷، ۱۸، ۱۹ و ۲۰ دایره بکشید.
Circle numbers 21 to 30.	دور اعداد ۲۱ تا ۳۰ دایره بکشید.
Circle the initial letters.	دور حروف ابتدایی دایره بکشید.
Count the capital letters. How many are they?	حروف بزرگ را بشمارید. چند حرف بزرگ وجود دارد؟
Find and circle the letters "e" and "p".	حروف "e" و "p" را پیدا کنید و دور آنها دایره بکشید.
Find and circle the letters "g" and "r".	حروف "g" و "r" را پیدا کنید و دور آنها دایره بکشید.
Find and circle the letters "s" and "x".	حروف "s" و "x" را پیدا کنید و دور آنها دایره بکشید.
Greet your friend and introduce your classmate to him/her.	با دوست خود سلام و احوال‌پرسی کنید و او را به همکلاسی‌تان معرفی کنید.
Introduce yourself to the class. Then, introduce your friend.	خودتان را به کلاس معرفی کنید. سپس دوستتان را معرفی کنید.
Join the alphabets to complete the picture and name it.	حروف الفبا را به هم وصل کنید و نام تصویر را بگویید.
Join the numbers from 21 to 30 and name the picture.	اعداد ۲۱ تا ۳۰ را به هم وصل کنید و نام تصویر را بگویید.
Join the numbers to complete the picture.	اعداد را (به ترتیب) به هم وصل کنید و تصویر را کامل کنید.
Listen.	گوش کنید.
Listen again and point to the pictures above.	دوباره گوش کنید و به تصاویر بالا اشاره کنید.
Listen and answer.	گوش کنید و جواب بدهید.

Listen and chant.	گوش کنید و آواز بخوانید.
Listen and check.	گوش کنید و علامت بزنید.
Listen and check the correct picture.	گوش کنید و تصویر صحیح را انتخاب کنید.
Listen and choose the correct answer.	گوش کنید و پاسخ صحیح را انتخاب کنید.
Listen and choose the correct picture.	گوش کنید و تصویر صحیح را انتخاب کنید.
Listen and choose the correct pictures.	گوش کنید و تصاویر صحیح را انتخاب کنید.
Listen and choose.	گوش کنید و انتخاب کنید.
Listen and circle the initial letters.	گوش کنید و دور حروف ابتدایی دایره بکشید.
Listen and circle.	گوش کنید و دایره بکشید.
Listen and circle the letters.	گوش کنید و دور حروف را دایره بکشید.
Listen and circle the letters in each word.	گوش کنید و دور حروف در هر کلمه را دایره بکشید.
Listen and number the body parts from 1 to 4.	گوش کنید و از شماره ۱ تا ۴ اعضای بدن را شماره گذاری کنید.
Listen and number the commands.	گوش کنید و دستورات را شماره گذاری کنید.
Listen and number the pictures as you hear.	گوش کنید و تصاویر را همان طور که می شنوید شماره گذاری کنید.
Listen and number the pictures.	گوش کنید و تصاویر را شماره گذاری کنید.
Listen and number the pictures. Then name each.	گوش کنید و تصاویر را شماره گذاری کنید. سپس نام هر یک را بگویید.
Listen and point.	گوش کنید و اشاره کنید.
Listen and repeat the dialogue.	گوش کنید و گفت و گو را تکرار کنید.
Listen and repeat.	گوش کنید و تکرار کنید.
Listen and trace.	گوش کنید و ردیابی کنید.
Listen and write.	گوش کنید و بنویسید.
Listen and write the missing letters.	گوش کنید و حروف جاافتاده را بنویسید.
Listen and write the missing numbers.	گوش کنید و اعداد جاافتاده را بنویسید.
Listen to the commands and act out what you hear.	به دستورها گوش کنید و آنچه را می شنوید انجام دهید.
Look and circle the initial letters.	نگاه کنید و دور حروف ابتدایی دایره بکشید.

Look and write the missing letters.	نگاه کنید و حروف جاافتاده را بنویسید.
Look at each picture and choose the correct letter.	به هر تصویر نگاه کنید و حرف صحیح را انتخاب کنید.
Look at the letters below and put the missing capital or small letter in each cell.	به حروف زیر نگاه کنید و در هر خانه حرف بزرگ یا کوچک جاافتاده را بنویسید.
Look at the pictures and complete the puzzles.	به تصاویر نگاه کنید و جدول ها را کامل کنید.
Look at the pictures and do the puzzles.	به تصاویر نگاه کنید و جدول ها را حل کنید.
Look at the pictures and find the words in the tables below.	به تصاویر نگاه کنید و لغات را در جدول های زیر پیدا کنید.
Look at the pictures and write the initial letters.	به تصاویر نگاه کنید و حروف ابتدایی آنها را بنویسید.
Look at the pictures and write "w" or "x".	به تصاویر نگاه کنید و حرف "w" یا "x" را بنویسید.
Look at the pictures on the top. Listen and repeat.	به تصاویر بالای صفحه نگاه کنید. گوش کنید و تکرار کنید.
Look at the pictures. Then, make your own dialogue.	به تصاویر نگاه کنید. سپس گفت و گوی خود را بسازید.
Make your own dialogue using the pattern above.	با استفاده از الگوی بالا، گفت و گوی خود را بسازید.
Match the capital letters with the small letters.	حروف بزرگ را به حروف کوچک وصل کنید.
Match the small letters with the capital letters.	حروف کوچک را به حروف بزرگ وصل کنید.
Match the pictures with the initial letters.	تصاویر را به حروف ابتدایی وصل کنید.
Number the pictures as you listen.	تصاویر را حین گوش دادن شماره گذاری کنید.
Number the seats from 10 to 20.	صندلی ها را از ۱۰ تا ۲۰ شماره گذاری کنید.
Point to each body part and ask your friend to name it.	به هر یک از اعضای بدن اشاره کنید و از دوستان بخواهید نام آن را بگویند.
Point to each number and ask your friend to read it.	به هر یک از شماره ها اشاره کنید و از دوستان بخواهید آن را بخوانند.
Point to each picture and ask your friend to give the command.	به هر تصویر اشاره کنید و از دوستان بخواهید تا دستور مرتبط را به شما بدهد [تا اجرا کنید].
Point to each picture and ask your friend to name it.	به هر تصویر اشاره کنید و از دوستان بخواهید نام آن را بگویند.
Point to each picture and ask your friend to read the number.	به هر تصویر اشاره کنید و از دوستان بخواهید عدد مورد نظر را بخوانند.

Point to each picture and ask your friend to tell the number of the items.	به هر تصویر اشاره کنید و از دوستان بخواهید تعداد هر کدام را بگویند.
Point to each picture and ask your friend to write down the initial letter.	به هر تصویر اشاره کنید و از دوستان بخواهید حرف اول کلمه را بنویسند.
Point to each watch and ask your friend to read it.	به هر یک از ساعتها اشاره کنید و از دوستان بخواهید آن را بخوانند.
Point to each word and ask your friend to read it.	به هر یک از کلمات اشاره کنید و از دوستان بخواهید آن را بخوانند.
Practice writing the following words.	نوشتن کلمات زیر را تمرین کنید.
Put the numbers from 1 to 20 to complete the calendar below.	شماره‌های ۱ تا ۲۰ را بنویسید تا تقویم زیر کامل شود.
Read aloud.	بلند بخوانید.
Say your phone number and ask your friend to write it down.	شماره تلفن خود را بگویید و از دوست خود بخواهید آن را بنویسد.
Sound out the letters in the words below.	صدای حروف را در کلمات زیر بگویید.
Stick a photo of your family and introduce them.	عکسی از خانواده خود بچسبانید و آنها را معرفی کنید.
Tick the capital letters.	حروف بزرگ را علامت بزنید.
Tick the small letters.	حروف کوچک را علامت بزنید.
Trace and write the letters.	ردیابی کنید و حروف را بنویسید.
Trace and write the numbers.	ردیابی کنید و اعداد را بنویسید.
Write down the missing small letters or capital letters.	حروف کوچک یا بزرگ جافتاده را بنویسید.
Write down what you hear.	آنچه را می‌شنوید بنویسید.
Write the missing letters to complete the words.	حروف جافتاده را بنویسید تا کلمات کامل شوند.
Write the missing numbers.	اعداد جافتاده را بنویسید.
Write the number of the letters.	تعداد حروف را بنویسید.

Worksheet for Letters

L

I

K

k

F

f

R

r

G

g

Q

q

S

s

Y

y

W

w

X

x

Worksheet for Words

ant

cat

hat

map

jam

ink

fig

van

hen

pen

bed

up

bag

lamp

lemon

zoo

book

park

oven

Audio Scripts

Review of Book 1

1.

1. Write.
2. Stand up.
3. Go out.
4. Open the book.
5. Clean the board.

2.

1. candy
2. tea
3. umbrella
4. zoo
5. jungle
6. van

3.

125 123 110 118 115

Lesson 1

1.

Mina: Good morning, Maryam.

Maryam: Good morning, Mina.

Mina: How are you?

Maryam: Fine, and you?

Mina: Fine.

2.

Sara Mina Maryam

3.

Mina: Hello, Ms. Tavana.

Ms. Tavana: Hello, Mina.

Mina: This is Maryam.

Ms. Tavana: Hello, Maryam.

Maryam: Hello, Ms. Tavana.

4.

Ms. Tavana

5.

1. This is Sara.

2. This is Mina.

3. This is Ms. Tavana.

4. This is Mr. Ahmadi.

6.

Sara: Good morning, Ms. Tavana.

Ms. Tavana: Good morning, Sara. How are you?

Sara: Fine.

7.

Mina: Good morning, Sara.

Sara: Good morning, Mina.

Mina: This is Maryam.

Sara: Hello, Maryam.

Maryam: Hello, Sara.

8.

K k [k]

L l [l]

9.

[k] key

[l] lamp

[k] kite

[l] lemon

10.

[k] key

[l] lamp

[k] kite

[l] lemon

11.

It's a key; "k", "k", key.

It's a kite; "k", "k", kite.

It's a lamp; "l", "l", lamp.

It's a lemon; "l", "l", lemon.

12.

1. lemon

2. kite

3. lamp

4. key

13.

lamp Key

14.

1. k 2. l

15.

1. kite 2. lamp 3. key 4. lemon

16.

1. key

2. lemon

3. kite

4. lamp

17.

11 12 13

18.

A.11 B.12 C.13

19.

-Goodbye. Goodbye.

-Bye. Bye.

20.

1. Good Morning.

2. Bye.

Lesson 2

1.

This is my mom.

This is my dad.

This is my brother.

This is my sister.

2.

mom dad brother sister

3.

1. This is my mom.

2. This is my dad.

3. This is my brother.

4. This is my sister.

4.

1. This is my mom.

2. This is my brother.

3. This is my sister.

4. This is my dad.

5.

1. This is my sister.

2. This is my dad.

3. This is my mom.

4. This is my brother.

6.

F f [f]

R r [r]

7.

[f] fish

[r] robot

[f] fire

[r] rain

8.

[f] fish

[r] robot

[f] fire

[r] rain

9.

It's a fish; "f", "f", fish.

It's a fire; "f", "f", fire.

It's a robot; "r", "r", robot.

It's the rain; "r", "r", rain.

10.

1. fire 2. rain 3. fish 4. robot

11.

rain fish

12.

1. f 2. r

13.

1. fish 2. robot 3. fire 4. rain

14.

1. robot 2. fire 3. rain 4. fish

15.

14 15 16

16.

A. 11 12 13

B. 14 15 16

Lesson 3

1.

This is my head.

This is my face.

This is my hand.

This is my back.

This is my leg.

2.

head face hand
back leg

3.

1. This is my face.

2. This is my hand.

3. This is my head.

4. This is my back.

5. This is my leg.

4.

- | | |
|---------------------|---------------------|
| 1. This is my head. | 2. This is my face. |
| 3. This is my hand. | 4. This is my leg. |

5.

- | | |
|-----|-----|
| G g | [g] |
| Q q | [k] |

6.

- | | |
|-----|-------|
| [k] | Quran |
| [g] | grass |
| [k] | quiz |
| [g] | gift |

7.

- | | |
|-----|-------|
| [k] | Quran |
| [g] | grass |
| [k] | quiz |
| [g] | gift |

8.

- It's a gift; "g", "g", gift.
It's grass; "g", "g", grass.
It's a quiz; "q", "q", quiz.
It's the Quran; "q", "q", Quran.

9.

- | | |
|----------|----------|
| 1. gift | 2. Quran |
| 3. grass | 4. quiz |

10.

- | | |
|-------|------|
| grass | quiz |
|-------|------|

11.

- | | |
|------|------|
| 1. g | 2. q |
|------|------|

12.

- | | | | |
|---------|---------|----------|----------|
| 1. gift | 2. quiz | 3. grass | 4. Quran |
|---------|---------|----------|----------|

13.

- | | | | |
|---------|----------|---------|----------|
| 1. gift | 2. Quran | 3. quiz | 4. grass |
|---------|----------|---------|----------|

14.

- | | | | |
|----|----|----|----|
| 17 | 18 | 19 | 20 |
|----|----|----|----|

15.

- | | | |
|-------|----|----|
| A. 11 | 12 | 13 |
| B. 14 | 15 | 16 |
| C. 17 | 18 | 19 |
| D. 20 | | |

Review 1

1.

1. This is my dad.
2. This is my sister.
3. This is my brother.
4. This is my mom.

2.

1. leg
2. back
3. hand
4. face
5. head

3.

- | | | | |
|------|------|------|------|
| 1. f | 2. k | 3. q | 4. r |
|------|------|------|------|

4.

- | | |
|----------|----------|
| 1. lemon | 2. key |
| 3. grass | 4. robot |

Lesson 4

1.

- It's hot.
- It's cold.
- It's sunny.
- It's rainy.
- It's snowy.

2.

- | | |
|-----------------|---------------|
| 1. Is it hot? | Yes, it is. |
| 2. Is it hot? | No, it isn't. |
| 3. Is it sunny? | Yes, it is. |
| 4. Is it sunny? | No, it isn't. |
| 5. Is it snowy? | Yes, it is. |
| 6. Is it snowy? | No, it isn't. |

3.

- 1. It's snowy.
- 2. It's rainy.
- 3. It's hot.
- 4. It's cold.
- 5. It's sunny.

4.

- | | |
|--------------|------|
| Is it sunny? | Yes. |
| Is it hot? | No. |

5.

- | | |
|--------------------------|---------------|
| 1. Is it rainy? | Yes, it is. |
| 2. Is it sunny and hot? | No, it isn't. |
| 3. Is it hot? | Yes, it is. |
| 4. Is it snowy? | Yes, it is. |
| 5. Is it cold and snowy? | No, it isn't. |

6.

- | | |
|-----|-----|
| S s | [s] |
| Y y | [j] |

7.

- | | |
|-----|--------|
| [s] | sun |
| [j] | yellow |
| [s] | soup |
| [j] | yard |

8.

- | | |
|-----|--------|
| [s] | sun |
| [j] | yellow |
| [s] | soup |
| [j] | yard |

9.

- It's the sun; "s", "s", sun.
- It's soup; "s", "s", soup.
- It's yellow; "y", "y", yellow.
- It's a yard; "y", "y", yard.

10.

- | | |
|---------|-----------|
| 1. soup | 2. yard |
| 3. sun | 4. yellow |

11.

- | | |
|-----|------|
| sun | yard |
|-----|------|

12.

1. s 2. y

13.

1. sun 2. yellow 3. soup 4. yard

14.

1. soup 2. yard
3. sun 4. yellow

15.

- | | | | | |
|----|----|----|----|----|
| 21 | 22 | 23 | 24 | 25 |
| 26 | 27 | 28 | 29 | 30 |

16.

- | | | |
|-------|----|----|
| A. 21 | 22 | 23 |
| B. 24 | 25 | 26 |
| C. 27 | 28 | 29 |
| D. 30 | | |

Lesson 5

1.

- Don't open your book.
Don't close the door.
Don't clean the board.

2.

- Don't open your book.
Don't close the door.
Don't clean the board.

3.

1. Don't close the door.
2. Don't clean the board.
3. Don't open your book.
4. Open your book.

4.

1. Don't open the book.
2. Close the door.
3. Don't clean the board.

5.

- | | |
|-----|------|
| W w | [w] |
| X x | [ks] |

6.

- | | |
|------|--------|
| [w] | wall |
| [ks] | box |
| [w] | window |
| [ks] | taxi |

7.

- | | |
|------|--------|
| [w] | wall |
| [ks] | box |
| [w] | window |
| [ks] | taxi |

8.

- It's a wall; "w", "w", wall.
It's a window; "w", "w", window.
It's a box; "x", "x", box.
It's a taxi; "x", "x", taxi.

9.

1. taxi
2. wall
3. box
4. window

10.

wall taxi

11.

1. "w" for wall; "x" in box.
2. "w" for window; "x" in taxi.

12.

1. wall 2. box 3. window 4. taxi

13.

1. window 2. taxi
3. wall 4. box

14.

I'm 31 32 33 34 35 36 37 38 39 40

How old are you?

I'm 16.

15.

1. 34 2. 37
3. 31 4. 40

16.

- A. 31 32 33
- B. 34 35 36
- C. 37 38 39
- D. 40

Lesson 6

1.

bedroom bathroom
kitchen living room

2.

Where is Mom? Mom is in the kitchen.
Where is Dad? Dad is in the bathroom.

3.

Where is Sina? He is in the bedroom.
Where is dad? He is in the bathroom.
Where is mom? She is in the kitchen.
Where is Mina? She is in the living room.

4.

1. Is mom in the living room? No.
2. Is dad in the bedroom? Yes.

5.

1. Is he in the bedroom? Yes, he is.
2. Is she in the kitchen? No, she isn't.
3. Is he in the living room? No, he isn't.
4. Is she in the kitchen? Yes, she is.

6.

1. Where is Mina? She is in the bedroom.
2. Where is Sina? He is in the living room.
3. Where is Mina? She is in the kitchen.
4. Where is Sina? He is in the bathroom.

7.

1. Where is dad? He is in the bathroom.
2. Where is Mina? She is in the bedroom.
3. Where is Sina? He is in the kitchen.
4. Where is mom? She is in the living room.

8.

41 42 43 44 45
46 47 48 49 50

9.

1. How old is Mom? She is 42.
2. How old is dad? He is 48.

10.

1. How old is she? She is 43.
2. How old is she? She is 47.
3. How old is he? He is 49.
4. How old is he? He is 50.

11.

A. 41 42 43
B. 44 45 46
C. 47 48 49
D. 50

Review 2

1.

1. Don't close the window.
2. Don't open the door.
3. Clean the board.

2.

1. Is it rainy?
2. Is it hot and sunny?
3. Is it snowy and cold?

3.

1. She is in the kitchen.
2. He is in the bedroom.
3. He is in the bathroom.
4. She is in the living room.

4.

1. w 2. x 3. s 4. y

5.

1. yard 2. sun
3. taxi 4. window

6.

1. Is he 35?
2. Is she 46?
3. Is she 50?
4. Is he 38?

Lesson 7

1.

1. Hello, where is Sina?
Hello, he is in the supermarket.
2. Hello, where is Mina?
Hello, she is in the hospital.
3. Mina, where is dad? He is in the school.
4. Mina, where is mom? She is in the bank.
5. Sina, where is Ali? He is in the mosque.

2.

bank supermarket mosque
hospital school

3.

- | | |
|--------------------------------------|----------------|
| 1. Is Mina in the hospital? | Yes, she is. |
| 2. Is dad in the school? | No, he isn't. |
| 3. Is Mr. Ahmadi in the bank? | Yes, he is. |
| 4. Is Ms. Tavana in the supermarket? | No, she isn't. |
| 5. Is Ali in the mosque? | Yes, he is. |

4.

- | | |
|-------------------------|---------------------------|
| 1. Where is Sina? | He is in the mosque. |
| 2. Where is Mina? | She is in the bank. |
| 3. Where is Ali? | He is in the hospital. |
| 4. Where is Mr. Ahmadi? | He is in the supermarket. |
| 5. Where is Ms. Tavana? | She is in the school. |

5.

- | | |
|-------------------------|----------------------------|
| 1. Where is Mr. Ahmadi? | He is in the school. |
| 2. Where is Mina? | She is in the hospital. |
| 3. Where is Sina? | He is in the bank. |
| 4. Where is Ms. Tavana? | She is in the mosque. |
| 5. Where is mom? | She is in the supermarket. |

6.

- | | | |
|----------------|-------------|---------|
| 1. mosque | 2. school | 3. bank |
| 4. supermarket | 5. hospital | |

7.

51 52 53 54 55 56 57 58 59 60

8.

- | | | | |
|-------|-------|-------|-------|
| 1. 52 | 2. 57 | 3. 55 | 4. 60 |
|-------|-------|-------|-------|

9.

- | | | |
|-------|----|----|
| A. 51 | 52 | 53 |
| B. 54 | 55 | 56 |
| C. 57 | 58 | 59 |
| D. 60 | | |

Lesson 8

1.

- | | |
|----------------|-----------|
| How many pens? | One pen. |
| | Two pens. |

2.

- | | |
|--------|-----------|
| pens | pencils |
| books | notebooks |
| chairs | bags |

3.

- | | |
|------------------------|----------------|
| 1. How many pencils? | Four pencils. |
| 2. How many notebooks? | Two notebooks. |
| 3. How many chairs? | Three chairs. |
| 4. How many bags? | Two bags. |

4.

- | |
|------------------------|
| 1. How many apples? |
| 2. How many kites? |
| 3. How many chairs? |
| 4. How many notebooks? |

5.

- | | | |
|-------|----|----|
| A. 17 | 13 | 29 |
| B. 19 | 30 | 11 |
| C. 10 | 26 | 22 |

Lesson 9

1.

It's white.

2.

It's brown.
It's pink.
It's white.
It's black.

3.

It's a pink pencil.

It's a brown pencil.

It's a black pencil.

It's a white pencil.

4.

What color is the bag? It's pink.

5.

What color is the bag? It's pink.

What color is the desk? It's brown.

What color is the bed? It's white.

What color is the printer? It's black.

6.

1. It is black. 2. It is pink.

3. It is brown. 4. It is white.

7.

1. It's a black book. 2. It's a brown bed.

3. It's a white sheep. 4. It's a pink candy.

8.

1. Is it a brown bag? No, it isn't.

2. Is it a black printer? Yes, it is.

3. Is it a pink pencil? Yes, it is.

4. Is it a white bed? No, it isn't.

9.

10:58 6:55

9:39 11:49

10.

A. 33 47 60

B. 52 44 36

C. 31 58 37

11.

1. 03:40 2. 10:39 3. 04:42 4. 11:50



Review 3

1.

1. She is in the mosque.

2. He is in the school.

3. She is in the hospital.

4. He is in the supermarket.

2.

1. What color is it? It's pink.

2. What color is it? It's black.

3. What color is it? It's white.

4. What color is it? It's brown.

3.

1. notebooks 2. pens

3. chair 4. bag

5. notebook 6. bags

4.

1. desk 2. leg 3. bed

4. oven 5. yard 6. lamp

5.

1. map 2. ant 3. bed

4. hen 5. red

